

Horizontal Pneumatic Clamps

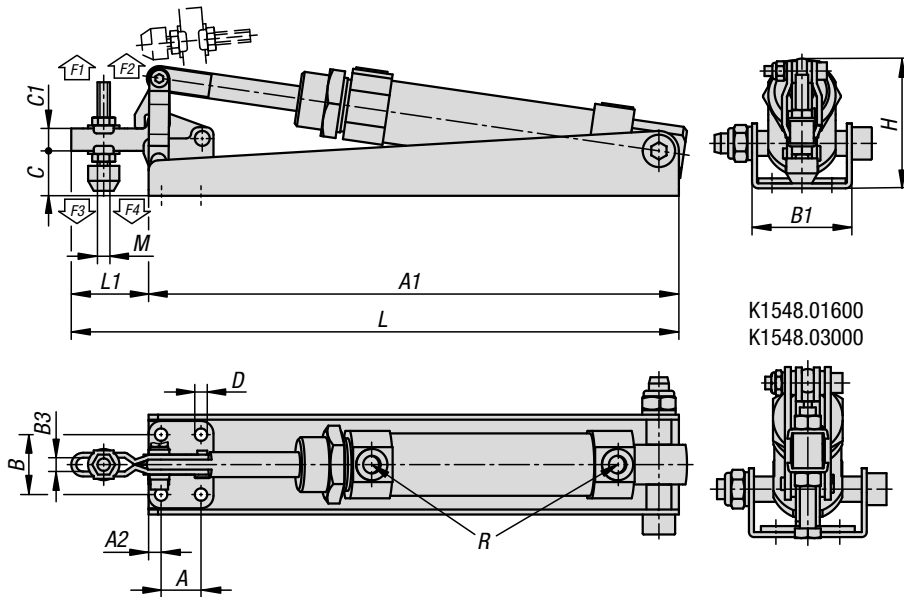

Material:

Lever parts and clamping spindle steel.

Version:

Lever parts trivalent passivated.
Clamping spindle and nuts phosphated.
Cylinder bright.

Sample order:

K1548.01000

Note:

A neoprene thrust pad is supplied with versions K1548.01000 and K1548.01200.

Pneumatic cylinder:

Double-acting without end of stroke dampening.

K1548.01600
K1548.03000

KIPP Horizontal Pneumatic Clamps

Order No.	Opening angle of holding arm	Air consumption per cycle	Holding force at 6 bar F1 N	Holding force at 6 bar F2 N	Clamping force at 6 bar F3 N	Clamping force at 6 bar F4 N	Operating pressure bar	strokes per min. at 6 bar
K1548.01000	70°	0,06 dm ³	1000	1500	800	1200	2 - 6	60
K1548.01200	85°	0,08 dm ³	1200	1800	1000	1500	2 - 6	60
K1548.01600	90°	0,28 dm ³	1600	2400	1200	1800	2 - 6	50
K1548.03000	85°	0,32 dm ³	3000	5400	2400	4800	2 - 6	50

Order No.	A	A1	A2	B	B1	B3	C	C1	D	H	L	L1	M	R
K1548.01000	16	212,5	5	24	40	5,5	18	9	4,5	52	243,5	31	M5x35	G1/8
K1548.01200	12,7	218	7	26,8	48	6,2	25	11	5,2	61,5	261	43	M6x50	G1/8
K1548.01600	19	270	8	32	59	8,9	34,5	17,5	7,1	85,2	345,2	75,2	M08x65	G1/8
K1548.03000	32	311,5	10	45	76	13,2	53,5	25	8,7	117,5	435,5	124	M12x100	G1/8