

Disc handwheels, aluminium without grip

Item description/product images

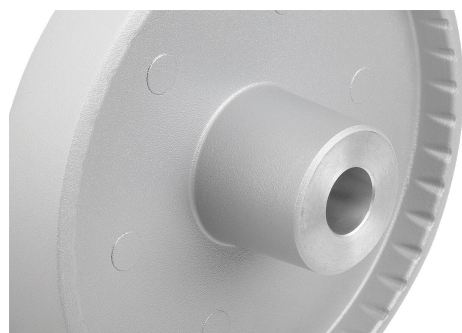
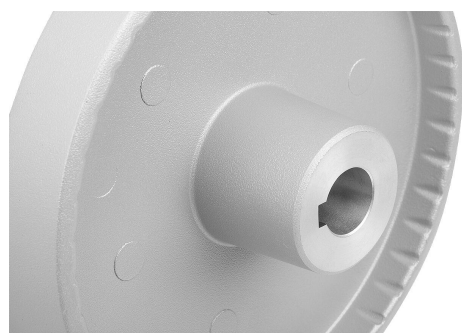
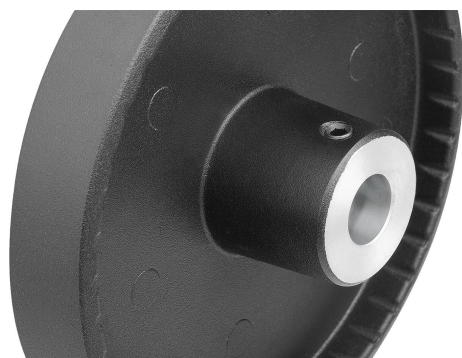

Description

Material:

Handwheel aluminium.

Hub cover black thermoplastic.

ISO 4027 grub screw, steel grade 45 H, black.

Version:

Black or silver powder-coated.

With reamed hole.

With reamed hole and keyway.

With reamed hole and transverse bore.

With reamed hole, keyway and transverse bore.

Note:

Wheel rim radial and axial run-out ≤ 0.4 mm.

Assembly:

The hub cover is supplied unassembled.

The handwheels can be secured to a shaft using a transverse pin or by parallel key connection together with a DIN 6912 cap screw and a handwheel washer K0173.

By the versions with transverse bore, fixation is carried out using an ISO 4027 grub screw.

Supplied with:

Aluminium handwheel.

Hub cover.

ISO 4027 grub screw (type with transverse bore).

Accessory:

K0173 Handwheel washers.

K1160 Socket head screws with low head DIN 6912.

Drawing reference:

1) Position of the transverse bore to the keyway is offset by 90° .

Disc handwheels, aluminium without grip

Item description/product images

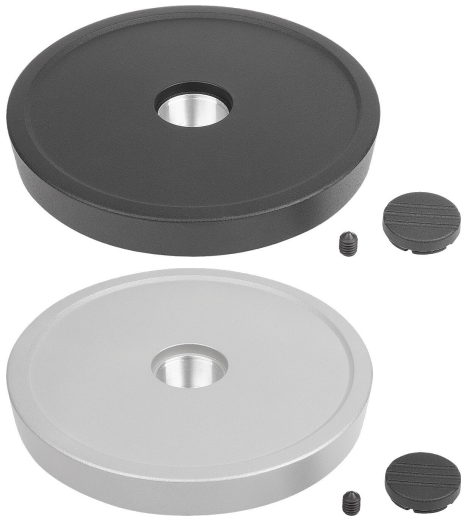

Drawings

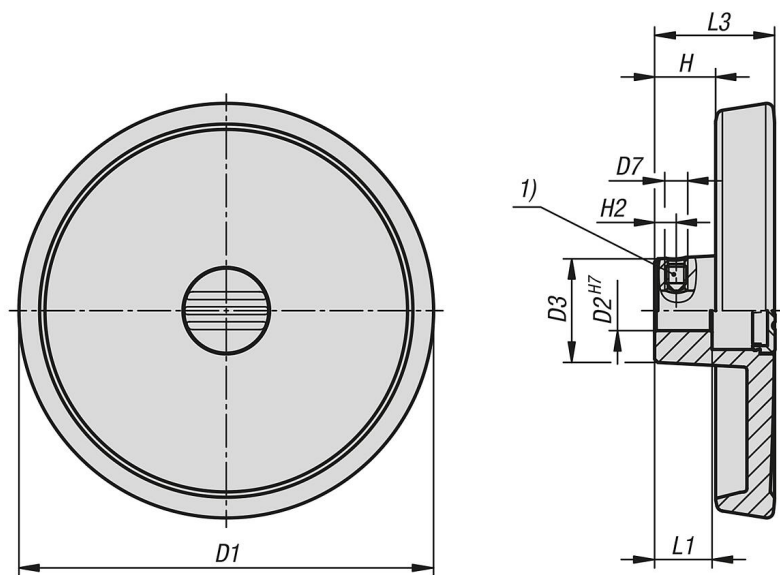

DIN 6885-1

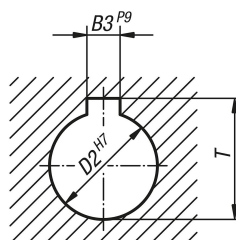

Overview of items

Disc handwheels, aluminium without grip

Disc handwheels, aluminium without grip

Overview of items

Order No.	Main colour	Form	Form definition	D1	D2	D3	L1	L3	H	H2	D7	B3	T
K1520.0801016	black	A	reamed hole with tranverse bore	80	10	26	16	29	16,6	5,5	M6	-	-
K1520.0801216	black	A	reamed hole with tranverse bore	80	12	26	16	29	16,6	6,5	M6	-	-
K1520.1001016	black	A	reamed hole with tranverse bore	100	10	28	17	33	17,5	5,5	M6	-	-
K1520.1001216	black	A	reamed hole with tranverse bore	100	12	28	17	33	17,5	6,5	M6	-	-
K1520.1251216	black	A	reamed hole with tranverse bore	125	12	31	18	36	18,3	6,5	M6	-	-
K1520.1251416	black	A	reamed hole with tranverse bore	125	14	31	18	36	18,3	6,5	M6	-	-
K1520.1401416	black	A	reamed hole with tranverse bore	140	14	36	19	39	19,3	6,5	M6	-	-
K1520.1401616	black	A	reamed hole with tranverse bore	140	16	36	19	39	19,3	8	M6	-	-
K1520.1601416	black	A	reamed hole with tranverse bore	160	14	36	20	40	20,2	6,5	M6	-	-
K1520.1601616	black	A	reamed hole with tranverse bore	160	16	36	20	40	20,2	8	M6	-	-
K1520.2001816	black	A	reamed hole with tranverse bore	200	18	42	24	45	24,3	8	M6	-	-
K1520.2002016	black	A	reamed hole with tranverse bore	200	20	42	24	45	24,3	8	M6	-	-
K1520.0801026	silver	A	reamed hole with tranverse bore	80	10	26	16	29	16,6	5,5	M6	-	-
K1520.0801226	silver	A	reamed hole with tranverse bore	80	12	26	16	29	16,6	6,5	M6	-	-
K1520.1001026	silver	A	reamed hole with tranverse bore	100	10	28	17	33	17,5	5,5	M6	-	-
K1520.1001226	silver	A	reamed hole with tranverse bore	100	12	28	17	33	17,5	6,5	M6	-	-
K1520.1251226	silver	A	reamed hole with tranverse bore	125	12	31	18	36	18,3	6,5	M6	-	-
K1520.1251426	silver	A	reamed hole with tranverse bore	125	14	31	18	36	18,3	6,5	M6	-	-
K1520.1401426	silver	A	reamed hole with tranverse bore	140	14	36	19	39	19,3	6,5	M6	-	-
K1520.1401626	silver	A	reamed hole with tranverse bore	140	16	36	19	39	19,3	8	M6	-	-
K1520.1601426	silver	A	reamed hole with tranverse bore	160	14	36	20	40	20,2	6,5	M6	-	-
K1520.1601626	silver	A	reamed hole with tranverse bore	160	16	36	20	40	20,2	8	M6	-	-
K1520.2001826	silver	A	reamed hole with tranverse bore	200	18	42	24	45	24,3	8	M6	-	-
K1520.2002026	silver	A	reamed hole with tranverse bore	200	20	42	24	45	24,3	8	M6	-	-
K1520.080101036	black	B	reamed hole with slot, with tranverse bore	80	10	26	16	29	16,6	5,5	M6	3	11,4
K1520.080121046	black	B	reamed hole with slot, with tranverse bore	80	12	26	16	29	16,6	6,5	M6	4	13,8
K1520.100101036	black	B	reamed hole with slot, with tranverse bore	100	10	28	17	33	17,5	5,5	M6	3	11,4
K1520.100121046	black	B	reamed hole with slot, with tranverse bore	100	12	28	17	33	17,5	6,5	M6	4	13,8
K1520.125121046	black	B	reamed hole with slot, with tranverse bore	125	12	31	18	36	18,3	6,5	M6	4	13,8
K1520.125141056	black	B	reamed hole with slot, with tranverse bore	125	14	31	18	36	18,3	6,5	M6	5	16,3
K1520.140141056	black	B	reamed hole with slot, with tranverse bore	140	14	36	19	39	19,3	6,5	M6	5	16,3
K1520.140161056	black	B	reamed hole with slot, with tranverse bore	140	16	36	19	39	19,3	8	M6	5	18,3
K1520.160141056	black	B	reamed hole with slot, with tranverse bore	160	14	36	20	40	20,2	6,5	M6	5	16,3
K1520.160161056	black	B	reamed hole with slot, with tranverse bore	160	16	36	20	40	20,2	8	M6	5	18,3
K1520.200181066	black	B	reamed hole with slot, with tranverse bore	200	18	42	24	45	24,3	8	M6	6	20,8
K1520.200201066	black	B	reamed hole with slot, with tranverse bore	200	20	42	24	45	24,3	8	M6	6	22,8
K1520.080102036	silver	B	reamed hole with slot, with tranverse bore	80	10	26	16	29	16,6	5,5	M6	3	11,4
K1520.080122046	silver	B	reamed hole with slot, with tranverse bore	80	12	26	16	29	16,6	6,5	M6	4	13,8
K1520.100102036	silver	B	reamed hole with slot, with tranverse bore	100	10	28	17	33	17,5	5,5	M6	3	11,4
K1520.100122046	silver	B	reamed hole with slot, with tranverse bore	100	12	28	17	33	17,5	6,5	M6	4	13,8
K1520.125122046	silver	B	reamed hole with slot, with tranverse bore	125	12	31	18	36	18,3	6,5	M6	4	13,8
K1520.125142056	silver	B	reamed hole with slot, with tranverse bore	125	14	31	18	36	18,3	6,5	M6	5	16,3
K1520.140142056	silver	B	reamed hole with slot, with tranverse bore	140	14	36	19	39	19,3	6,5	M6	5	16,3
K1520.140162056	silver	B	reamed hole with slot, with tranverse bore	140	16	36	19	39	19,3	8	M6	5	18,3
K1520.160142056	silver	B	reamed hole with slot, with tranverse bore	160	14	36	20	40	20,2	6,5	M6	5	16,3
K1520.160162056	silver	B	reamed hole with slot, with tranverse bore	160	16	36	20	40	20,2	8	M6	5	18,3
K1520.200182066	silver	B	reamed hole with slot, with tranverse bore	200	18	42	24	45	24,3	8	M6	6	20,8
K1520.200202066	silver	B	reamed hole with slot, with tranverse bore	200	20	42	24	45	24,3	8	M6	6	22,8
K1520.08010103	black	C	reamed hole with slot	80	10	26	16	29	16,6	-	-	3	11,4
K1520.08012104	black	C	reamed hole with slot	80	12	26	16	29	16,6	-	-	4	13,8
K1520.10010103	black	C	reamed hole with slot	100	10	28	17	33	17,5	-	-	3	11,4
K1520.10012104	black	C	reamed hole with slot	100	12	28	17	33	17,5	-	-	4	13,8
K1520.12512104	black	C	reamed hole with slot	125	12	31	18	36	18,3	-	-	4	13,8
K1520.12514105	black	C	reamed hole with slot	125	14	31	18	36	18,3	-	-	5	16,3
K1520.08010203	silver	C	reamed hole with slot	80	10	26	16	29	16,6	-	-	3	11,4
K1520.08012204	silver	C	reamed hole with slot	80	12	26	16	29	16,6	-	-	4	13,8
K1520.10010203	silver	C	reamed hole with slot	100	10	28	17	33	17,5	-	-	3	11,4
K1520.10012204	silver	C	reamed hole with slot	100	12	28	17	33	17,5	-	-	4	13,8
K1520.12512204	silver	C	reamed hole with slot	125	12	31	18	36	18,3	-	-	4	13,8
K1520.12514205	silver	C	reamed hole with slot	125	14	31	18	36	18,3	-	-	5	16,3
K1520.080101	black	E	with reamed hole	80	10	26	16	29	16,6	-	-	-	-
K1520.080121	black	E	with reamed hole	80	12	26	16	29	16,6	-	-	-	-

Disc handwheels, aluminium without grip

Overview of items

Order No.	Main colour	Form	Form definition	D1	D2	D3	L1	L3	H	H2	D7	B3	T
K1520.100101	black	E	with reamed hole	100	10	28	17	33	17,5	-	-	-	-
K1520.100121	black	E	with reamed hole	100	12	28	17	33	17,5	-	-	-	-
K1520.125121	black	E	with reamed hole	125	12	31	18	36	18,3	-	-	-	-
K1520.125141	black	E	with reamed hole	125	14	31	18	36	18,3	-	-	-	-
K1520.080102	silver	E	with reamed hole	80	10	26	16	29	16,6	-	-	-	-
K1520.080122	silver	E	with reamed hole	80	12	26	16	29	16,6	-	-	-	-
K1520.100102	silver	E	with reamed hole	100	10	28	17	33	17,5	-	-	-	-
K1520.100122	silver	E	with reamed hole	100	12	28	17	33	17,5	-	-	-	-
K1520.125122	silver	E	with reamed hole	125	12	31	18	36	18,3	-	-	-	-
K1520.125142	silver	E	with reamed hole	125	14	31	18	36	18,3	-	-	-	-