

Clamping pin, steel or stainless steel

with clamping angle

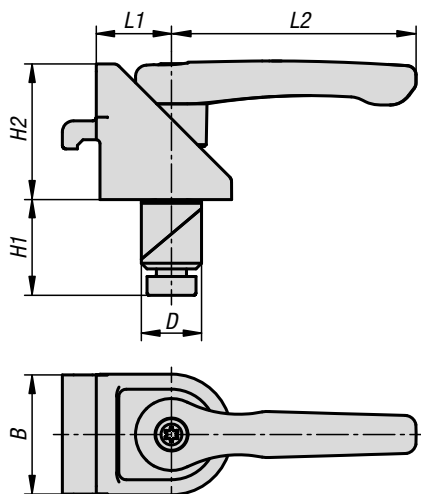

Material:

Handle die-cast zinc acc. to DIN EN 12844.

Clamping angle die-cast zinc.

Wedges steel 1.0715 or stainless steel 1.4305.

Version:

Handle black, plastic coated.

Wedges black oxidised or blank.

Sample order:

K1505.016

Note:

The clamping angles are suitable for fixating aluminium profiles on to grid hole tables or plates with Ø16 mm, Ø20 mm or Ø28 mm holes, e.g. an end stops. Loosen the clamping lever to detract the wedges and enable free rotation and movement. Clamping pins with clamping angles are mostly used in pairs.

Advantages:

Functions also in thin table material (metal: ≥8 mm or ≥4 mm ; wood ≥18 mm).

Gentle clamping in the bore.

Tool-less operation.



KIPP Clamping pin steel or stainless steel with clamping angle

Order No.	Main material	B	D	H1	H2	L1	L2
K1505.016	steel	32	16	25	36	20	65
K1505.120	stainless steel	32	20	21	36	20	65
K1505.028	steel	32	28	36	36	20	65