

Indexing plunger, stainless steel

with remote actuation

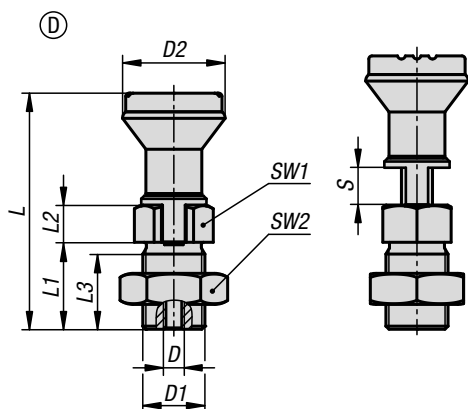
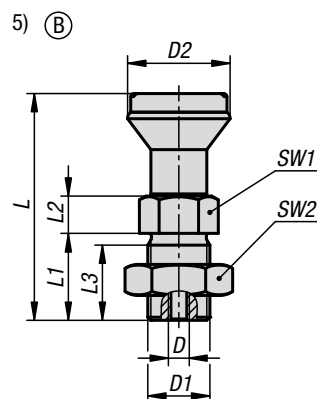
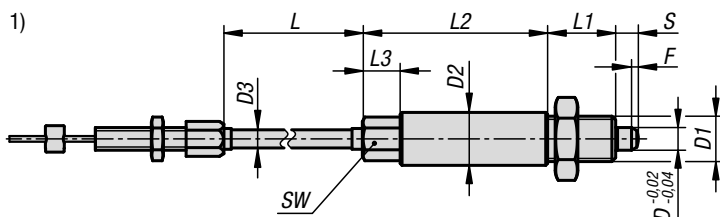

Indexing plungers are used where any change in locking position due to lateral forces should be prevented.

Some examples of this are for length, height and position indexing in machine, furniture and special vehicle construction.

Indexing plungers with remote actuation are used where inaccessible assembly spaces are making it difficult to operate, or where remote actuation is required for ergonomic or safety reasons.

The indexing plunger is connected to the operator side by a Bowden cable. The combination of indexing plunger and actuating element forms a complete system which can be used for many types of application. Form D should be used for applications where the indexing pin should remain disengaged for an extended period and be prevented from springing back.

As an alternative to the actuating element, the supplied screw nipple ($\emptyset 5 \times 7$ mm) can be used to integrate an individual actuating element into the system.

The Bowden cable is available in various lengths. To ensure an exact fit in the application concerned, the Bowden cable can be shortened as required during installation.

Corrosion protection is achieved by selecting a suitable material and surface treatment. The wire cable or cable sheath can be easily replaced if required.

Material:

Indexing plunger:

Threaded sleeve stainless steel 1.4305.

Indexing pin stainless steel 1.4034.

Actuating element stainless steel 1.4305.

Mushroom grip thermoplastic.

Plastic cap thermoplastic.

Wire cable stainless steel 1.4401.

Traction sleeve steel wire with plastic sleeving inside and outside.

End sleeves, setscrews and screw nipples brass.

Version:

Indexing pin, hardened, ground and bright.

Bowden cable casing, black.

Mushroom grip, thermoplastic dark grey.

Sample order:

K1502.02206X1000 (include length L)

Note for ordering:

Indexing plungers with remote actuation and actuating element must be ordered separately.

Indexing plunger, stainless steel

with remote actuation

Note:

When installing the Bowden cables, the following points should be noted:

The length of the free end of the cable can change due to the layout angle, bending radius and load factors. So, after laying the Bowden cable, the length of the counter-bearing (casing) must be adjusted using the adjusting screw supplied. The adjusting screw is also used to set the pretension in the Bowden cable system.

When laying the cable, particular care must be taken to ensure that the bending radius is not below the minimum value, which in this case is $R = 65 \text{ mm}$. A radius which is too narrow can lead to increased wear and higher friction.

Also avoid letting the bending radius briefly go below the minimum value when installing, as this can cause damage to the casing. Also, the casing is designed only to support pressure forces. If pulled too sharply, the inner coil will be stretched and permanently damaged.

On request:

Special versions.

Supplied with:

Indexing plunger with remote actuation:

Indexing plunger with preassembled cable, casing, end sleeve, adjusting screw M6 x 34 mm and screw nipple $\varnothing 5 \times 7 \text{ mm}$.

Actuating element:

Actuating element with plastic cover.

Accessories:

Hexagon nuts K0700.

Mounting brackets K0638.

Spacer rings K0665.

Positioning bushes K1290.

Actuating element K1502.12420.

Drawing reference:

- 1) Indexing plunger
- 2) Bowden cable casing
- 3) Bowden cable
- 4) Adjusting screw
- 5) Actuating element
- 6) Screw nipple
- 7) Cover

Form B: non-lockout type, with locknut

Form D: lockout type, with locknut

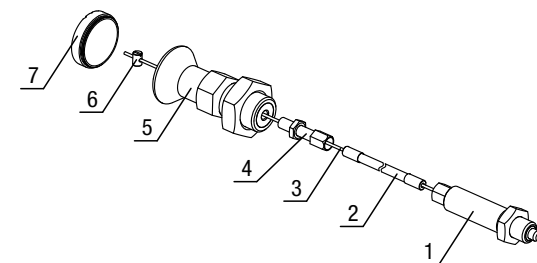

KIPP Indexing plunger, stainless steel with remote actuation

Order No.	D	D1	D2	D3	L	L1	L2	L3	Travel S	SW	Fx30°	Spring force initial pressure F1 approx. N	Spring force final pressure F2 approx. N
K1502.02206X	6	M12x1,5	14	5	1000/3000/5000	18	49	10	6	10	1,8	6	14
K1502.02308X	8	M16x1,5	19	5	1000/3000/5000	23	59	10	8	13	2,3	15	35
K1502.02410X	10	M20x1,5	23	5	1000/3000/5000	24	65	10	10	16	2,8	15	34
K1502.02412X	12	M20x1,5	23	5	1000/3000/5000	26	65	10	12	16	2,8	15	39

KIPP Actuating elements

Order No.	Form	Colour Cap	D Internal thread	D1	D2	L	L1	L2	L3	SW1	SW2
K1502.12420	B	black grey RAL 7021	M6	M20x1,5	33	73	28	12	25	22	30
K1502.124201	B	orange RAL 2004	M6	M20x1,5	33	73	28	12	25	22	30
K1502.124202	B	signal green RAL6032	M6	M20x1,5	33	73	28	12	25	22	30
K1502.124203	B	blue RAL5017	M6	M20x1,5	33	73	28	12	25	22	30
K1502.124205	B	light grey RAL 7035	M6	M20x1,5	33	73	28	12	25	22	30
K1502.124206	B	traffic red RAL 3020	M6	M20x1,5	33	73	28	12	25	22	30
K1502.124207	B	colza yellow RAL 1021	M6	M20x1,5	33	73	28	12	25	22	30

Order No. Travel S 6	Order No. Travel S 8	Order No. Travel S 10	Order No. Travel S 12	Form	Colour Cap	D Internal thread	D1	D2	L	L1	L2	L3	SW1	SW2
K1502.1442006	K1502.1442008	K1502.1442010	K1502.1442012	D	black grey RAL 7021	M6	M20x1,5	33	76	28	12	25	22	30
K1502.14420106	K1502.14420108	K1502.14420110	K1502.14420112	D	orange RAL 2004	M6	M20x1,5	33	76	28	12	25	22	30
K1502.14420206	K1502.14420208	K1502.14420210	K1502.14420212	D	signal green RAL6032	M6	M20x1,5	33	76	28	12	25	22	30
K1502.14420306	K1502.14420308	K1502.14420310	K1502.14420312	D	blue RAL5017	M6	M20x1,5	33	76	28	12	25	22	30
K1502.14420506	K1502.14420508	K1502.14420510	K1502.14420512	D	light grey RAL 7035	M6	M20x1,5	33	76	28	12	25	22	30
K1502.14420606	K1502.14420608	K1502.14420610	K1502.14420612	D	traffic red RAL 3020	M6	M20x1,5	33	76	28	12	25	22	30
K1502.14420706	K1502.14420708	K1502.14420710	K1502.14420712	D	colza yellow RAL 1021	M6	M20x1,5	33	76	28	12	25	22	30