

Oil level gauges

with electronic oil level monitoring, long version

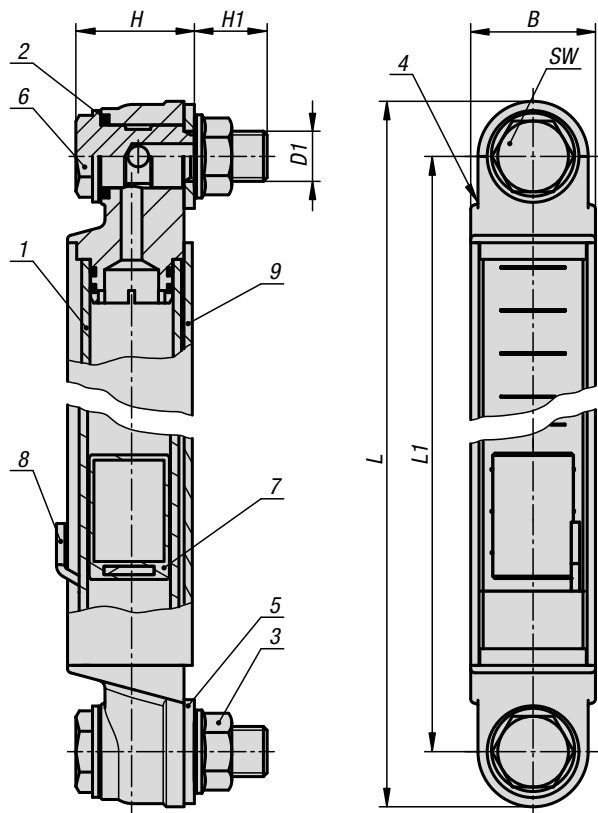

Drawing reference:

- 1) Sight glass
- 2) O-ring
- 3) M12 flange nut
- 4) Plastic end cap
- 5) Flat seal
- 6) M12 hollow screw
- 7) Float with magnet
- 8) Reed switch
- 9) Aluminium housing

Material:

Housing aluminium.
 Tube polycarbonate.
 Caps polyamide.
 O-ring and flat seal NBR.
 Reflector PVC.
 Float plastic.
 Screws and nuts, steel.

Version:

Sight glass crystal clear.
 Reflector white.
 Float red, with magnetic element.
 Screws and nuts electro zinc-plated.

Sample order:

K1428.300

Note:

The oil level gauge not only enables the oil level to be viewed but also recorded using a REED switch. If the float element reaches the selected minimum value after the circuit has been closed, the system emits an electric signal.

The sensor is located on the sight glass and its height can be adjusted in line with the control requirements for the oil level. The minimum level is around 50 mm from the centre of the lower fastening screw.

The reed switch is equipped with a normally open (NO) contact as standard.

The maximum pressure is 1 bar. The maximum tightening torque of the fastening screws is 5 Nm.

The sight glass has high mechanical strength and is resistant to mineral oil, petrol, lubricants, petroleum, solvents and most chemical substances. Avoid contact with alcoholic solutions and hot water.

Temperature range:

Maximum operating temperature: 75 °C.

Assembly:

The oil level gauge is secured using two M12 tapped holes or, two 12.2 mm (± 0.2 mm) holes and flange nuts. Centre distance for the fastening holes = $L1 \pm 0.5$.

Function:

The oil level is measured using a float element with a magnet that activates the electrical contact when the REED level switch is reached. If the oil level falls below a particular level, an electrical pulse can be emitted.

Attention:

Strong magnetic fields can impair function.

KIPP Oil level gauge with electric oil level monitoring, long version

Order No.	B	D1	H	H1	L	L1	SW	Number of fastening screws
K1428.300	30	M12	30	16,5	326,6	300	17	2
K1428.400	30	M12	30	16,5	426,6	400	17	2
K1428.500	30	M12	30	16,5	526,6	500	17	2