

Oil level gauges

with electronic oil level monitoring



Material:

Housing fibreglass reinforced thermoplastic polyamide.
Sight glass thermoplastic polyamide.
O-ring and flat seal NBR.
Reflector PVC.
Float plastic.
Screw and nut, steel.

Version:

Housing black.
Sight glass crystal clear, high mechanical stability, non-ageing.
Reflector white.
Float red, with magnetic element.
Screw and nut electro zinc-plated.

Sample order:

K1425.12712

Note:

The oil level gauge not only enables the oil level to be viewed but also recorded using a REED switch. When the float element reaches the selected minimum value after the circuit has been closed, the system emits an electric signal.

The sensor is located on the housing and its height can be adjusted in line with the control requirements for the oil level. The minimum level is ca. 35 mm from the centre of the lower fastening screw.

The reed switch is equipped with a normally open (NO) contact as standard. The sight glass consists of two transparent components which are ultrasonically welded together following assembly. This ensures a seal around the entire body.

The maximum pressure is 1 bar. The maximum tightening torque of the fastening screws is 5 Nm.

The sight glass has high mechanical strength and is resistant to mineral oil, petrol, lubricants, petroleum, solvents and most chemical substances. Avoid contact with alcoholic solutions and hot water.

Temperature range:

Maximum operating temperature: 75 °C.

Assembly:

The oil level gauge is secured using two M12 tapped holes or, two 12.2 mm (± 0.2 mm) holes and flange nuts. Centre distance for the fastening holes = $L1 \pm 0.3$.

Function:

The oil level is measured using a float element with a magnet that activates the electrical contact when the REED level switch is reached. If the oil level falls below a particular level, an electrical pulse can be emitted.

Attention:

Strong magnetic fields can impair function.

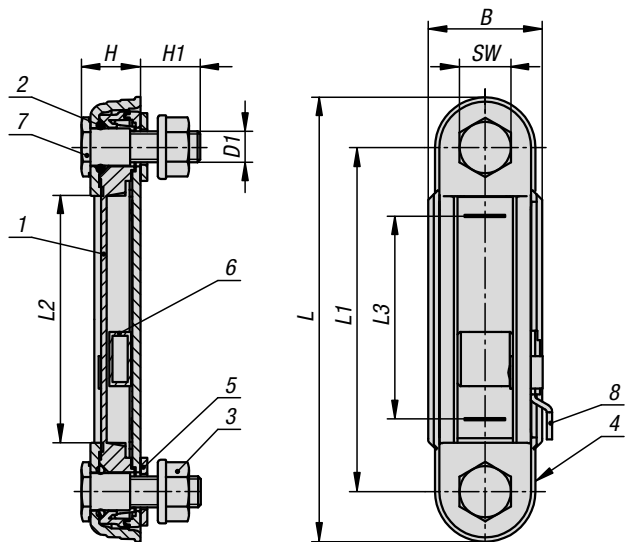

Drawing reference:

- 1) Sight glass
- 2) O-ring
- 3) M12 flange nut
- 4) Housing
- 5) Flat seal
- 6) Float with magnet
- 7) M12 hollow screw
- 8) Reed switch

KIPP Oil level gauge with electric oil level monitoring

| Order No. | B | D1 | H | H1 | L | L1 | L2 | L3 | SW | Number of fastening screws |
|-------------|----|-----|----|----|-----|-----|----|----|----|----------------------------|
| K1425.12712 | 42 | M12 | 21 | 21 | 164 | 127 | 91 | 75 | 19 | 2 |