

Strap hinges,

steel or stainless steel



Material:

Steel.
Stainless steel 1.4301.

Version:

Steel electro zinc-plated, chromed or matt brass plated.
Stainless steel matt polished. Steel electro zinc-plated, chromed or matt brass plated.
Stainless steel matt polished.

Sample order:

K1347.0541041222200 K1347.0541041222200

Note:

Strap hinge for in-frame doors.
The opening angle is max. 270°.

The loading values given for the hinges are non-binding reference values without consideration of safety factors and exclude any liability. The values given are for information purposes only and do not constitute a legally binding assurance of properties. These load values were determined under laboratory conditions. Each user must determine individually whether the hinge is suitable for the respective application. Different materials onto which the hinges are installed, the type of mounting, weather conditions and wear can influence the determined values.

Drawing reference:

- 1) Both rolled ends of long leaf are welded
- 2) Grease nipple
- 3) Fixed pin

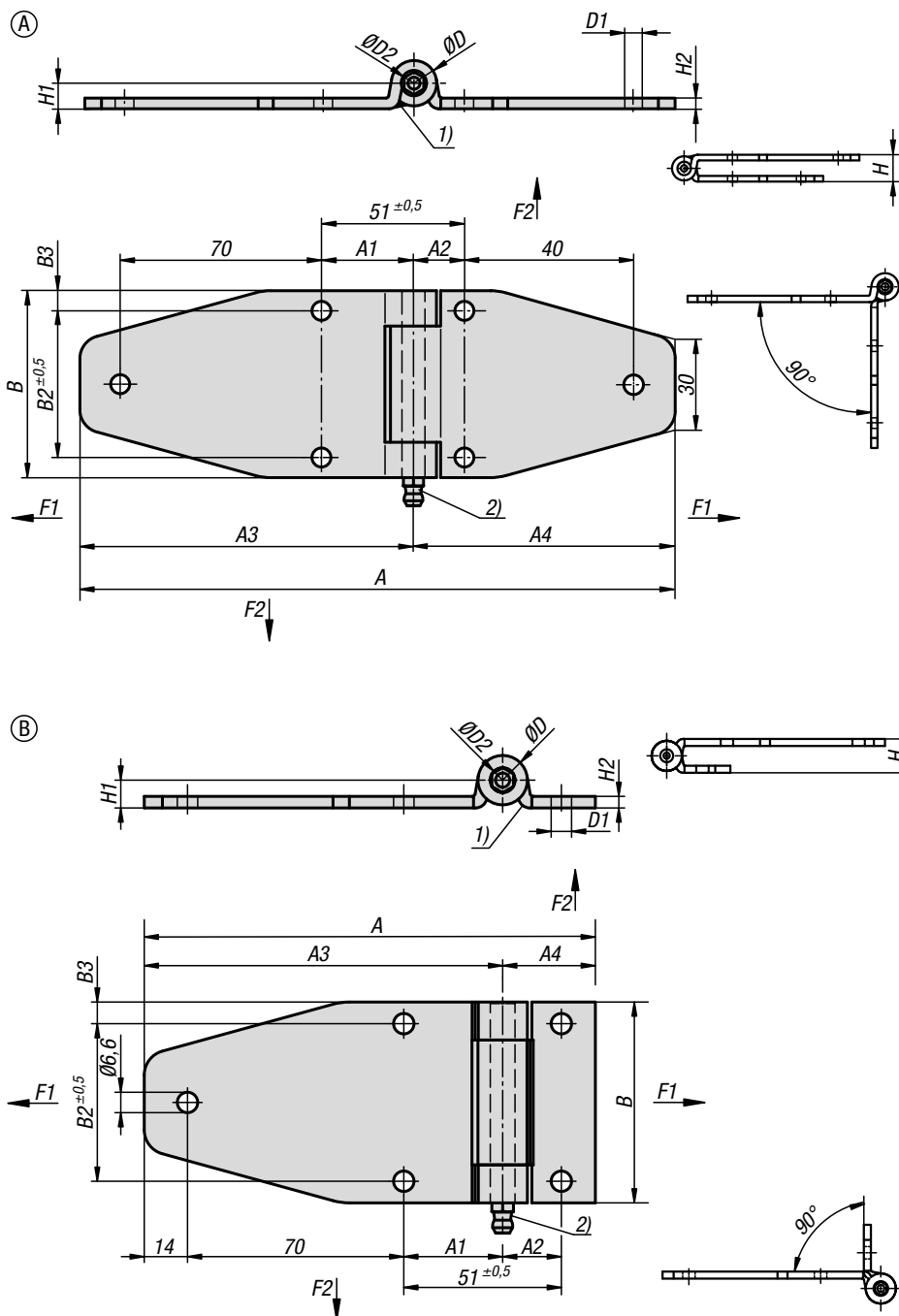

KIPP Strap hinges, steel or stainless steel

Order No.	Form	Form definition	Main material	Surface finish body	A	A1	A2	A3	A4	B	B2	B3	F1 N	F2 N
K1347.06701161932	A	longer leaf	stainless steel A2	matt polished	186	32	19	116	70	65	51	7	-	2500
K1347.067011619321	A	longer leaf	steel	galvanised	186	32	19	116	70	65	51	7	7500	1300