

Down-thrust clamps

Item description/product images



Description

Material:
Steel.

Version:
Case-hardened, black oxidised and ground.

Note:

The clamping heights can be increased with riser bars K0018 and for K1231.12 to K1231.14 and K1231.22 to K1231.24 reduced by self-aligning pads K0282.

The clamps have the following advantages:

- rapid clamping by hand via threaded spindle and spiral cam.
- quick and easy workpiece exchange by pivoting the clamp arm.
- compact design, small clamping space required.
- simple adaptation to tall clamping heights using the riser cylinders.

The clamps can be mounted in two ways:

- 1) in a T-slot.
- 2) by the M12 screw directly in a fixture base.

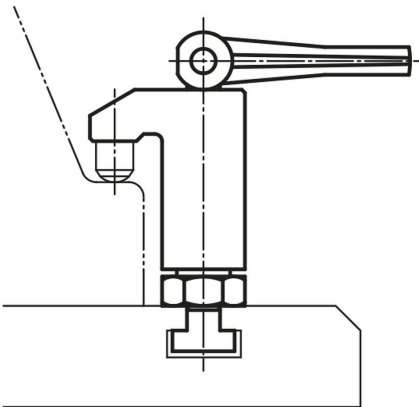

Drawings

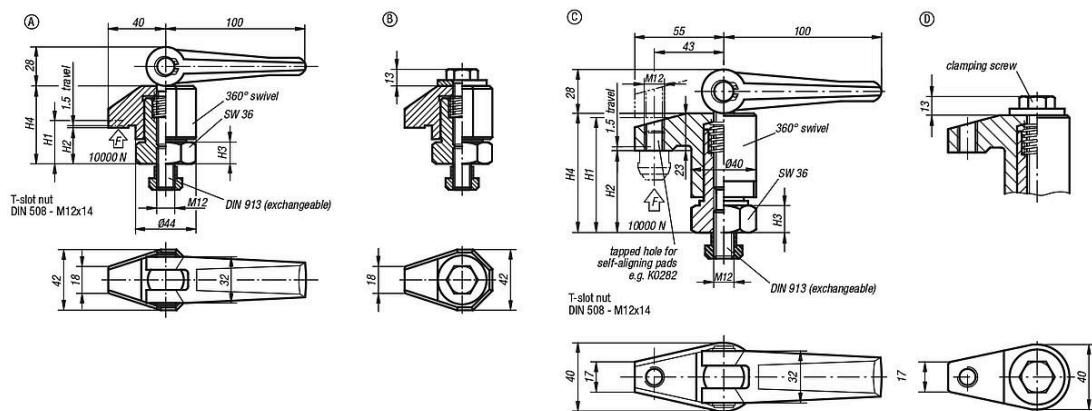

Overview of items

Down-thrust clamps

Overview of items

Down-thrust clamps

Order No.	Form	Form definition	Clamping height max. H1	Clamping height min. H2	H3	H4
K1231.11	A	with cam lever	30	25	15	54-59
K1231.12	C	with cam lever and thread	70	50	15	73-93
K1231.13	C	with cam lever and thread	98	68	15	91-121
K1231.14	C	with cam lever and thread	135	95	22	118-158
K1231.21	B	with clamping screw	30	25	15	54-59
K1231.22	D	with clamping screw and thread	70	50	15	73-93
K1231.23	D	with clamping screw and thread	98	68	15	91-121
K1231.24	D	with clamping screw and thread	135	95	22	118-158