

Handwheels

DIN 950, stainless steel

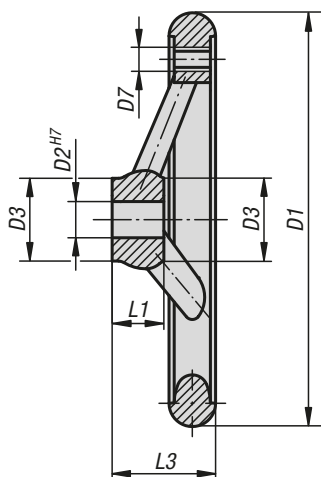
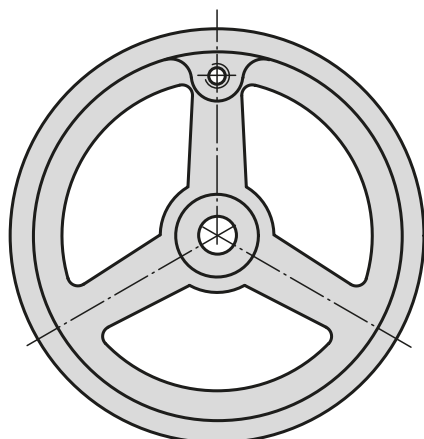

Material:
Stainless steel 1.4401.

Version:
Wheel rim turned
and polished

Sample order:
K1208.0100X10

DIN 6885-1

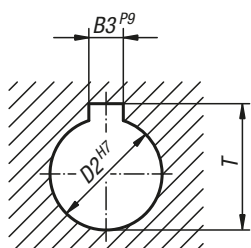

KIPP Handwheels DIN 950, stainless steel

Order No.	Version 1	D1	D2	D3	D7	L1	L3	B3	T	No. of spokes
K1208.0100X10	reamed hole	100	10H7	26	M6	17	33	-	-	3
K1208.0125X12	reamed hole	125	12H7	28	M8	18	36	-	-	3
K1208.0160X16	reamed hole	160	16H7	32	M10	20	40	-	-	3
K1208.0200X18	reamed hole	200	18H7	38	M10	24	45	-	-	3
K1208.1100X10	reamed hole with slot	100	10H7	26	M6	17	33	3	11,4	3
K1208.1125X12	reamed hole with slot	125	12H7	28	M8	18	36	4	13,8	3
K1208.1160X16	reamed hole with slot	160	16H7	32	M10	20	40	5	18,3	3
K1208.1200X18	reamed hole with slot	200	18H7	38	M10	24	45	6	20,8	3