

Centring clamps

round



Material:

Carbon steel.

Version:

Hardened (33–39 HRC) and black oxidised.

Sample order:

K1166.10804

Note:

The centring clamp enables a workpiece to be centred and clamped in the bore.

The wedges generate higher clamping forces.

The centring clamp is available with a cap screw or countersunk screw.

Centring clamp with pull-down effect.

Drawing reference:

Form A: with countersunk screw

Form B: with cap screw

Dimension H refers to the height at $\geq D$.

Dimension L refers to the length at $\leq D$

1) O-ring

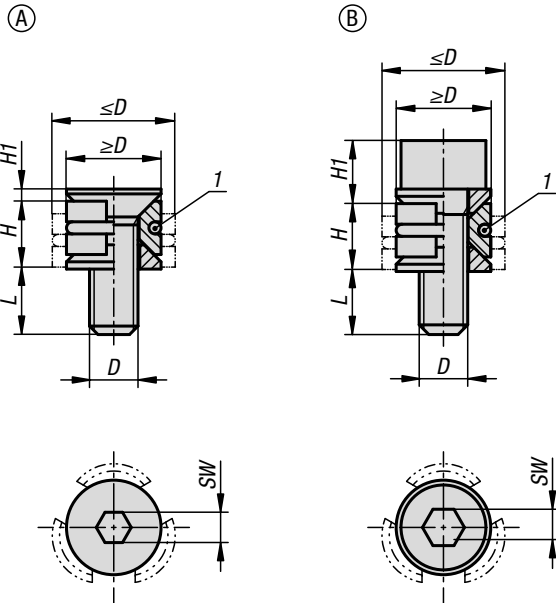

KIPP Centring clamp round

Order No.	Form	D	D min.	D max.	H	H1	L	SW	Clamping force max. kN	Tightening torque Nm
K1166.10804	A	M4x12	8	10,3	5,5	0,9	7,3	2,5	0,9	2,1
K1166.11005	A	M5X15	10	12,3	6,4	1,1	9,1	3	1,5	4,3
K1166.11206	A	M6X18	12	16,3	8,6	1,3	11,2	4	2,1	7,3
K1166.11608	A	M8X25	16	22	11,5	1,6	16,2	5	4	18
K1166.20804	B	M4x12	8	10,3	5,5	5,1	7,1	3	1,5	2,7
K1166.21005	B	M5X15	10	12,3	6,4	6,2	9	4	2,5	5,4
K1166.21206	B	M6X18	12	16,3	8,6	7,9	10,6	5	5	9,1
K1166.21608	B	M8X25	16	22	11,5	10,4	15,4	6	9	25

Centring clamps

round

Technical information:

- These clamps grip the inside diameter of a workpiece.
- The wedge shape enables high clamping forces on the workpiece.

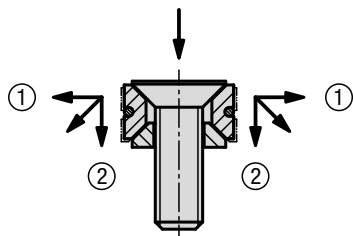

- (Jaws exert positive down force)
- ① Horizontal thrust against workpiece
 - ② Vertical thrust prevents the workpiece lifting

Form A:

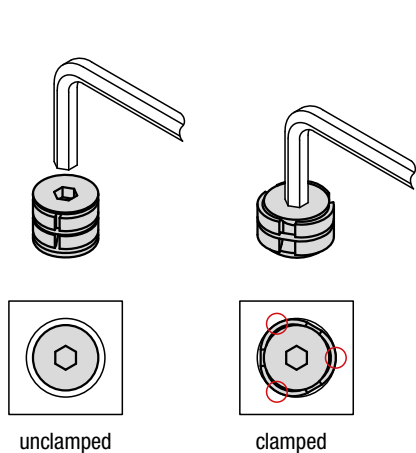

Form B:

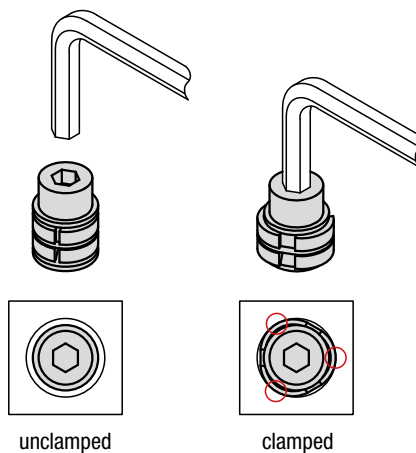

Note:

The clamp makes point contact with the bore wall when clamped.

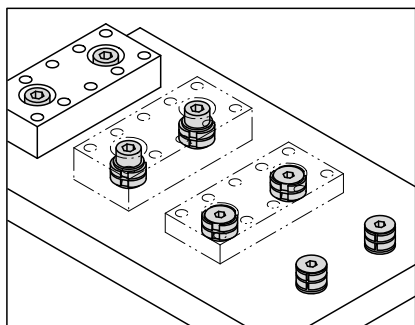

For accurate repeat positioning use these clamps together with a positioning unit. Clamping is carried out with the centring clamp.

