

Indexing plungers

pneumatic

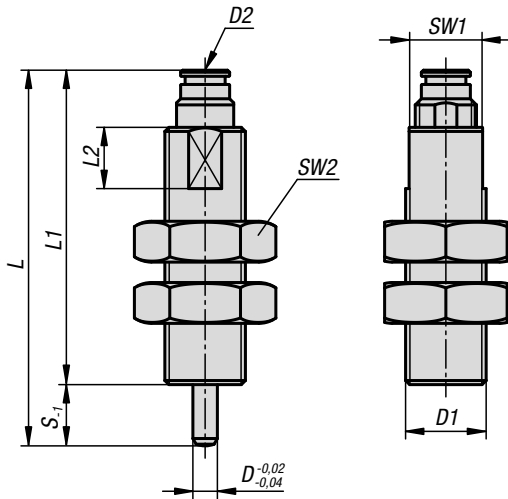

Material:

Steel version:
threaded sleeve and thrust pin, free-cutting steel.
hexagon nuts, steel, grade 04.

Stainless steel version:
threaded sleeve 1.4305
thrust pin 1.4034
hexagon nuts, A2 stainless steel.

Version:

Steel version:
threaded sleeve, black oxidised
thrust pin hardened, black oxidised and ground
hexagon nuts, black oxidised

Stainless steel version:
threaded sleeve, bright
thrust pin, hardened, ground and bright
hexagon nuts, bright

Sample order:

K1116.1206010

Note:

The indexing plungers are operated by applying compressed air.
The spring-loaded reset occurs by disconnecting the air supply.

Pneumatic cylinder:

Single-acting piston rod cylinder.

Materials:

cylinder tube, nickel-plated brass,
piston rod, stainless steel
seals, NBR, PU.

Operating medium:

filtered and dried air, oiled or not oiled.

Application temperature: -20 °C to +80 °C.

KIPP Indexing plungers, pneumatic

Order No. steel	Order No. stainless steel	D	D1	D2	L	L1	L2	Travel S	SW1	SW2	Operating pressure bar	Piston force at 6 bar (N)	Spring retraction force ca. N
K1116.1308010	K1116.01308010	8	M20x1,5	M5	77	67	15	10	18	30	2 - 6	39,6-35,3	11,6-5,1
K1116.1206010	K1116.01206010	6	M20x1,5	M5	80	70	15	10	18	30	2 - 6	38,7-35,1	9,9-6
K1116.1308015	K1116.01308015	8	M20x1,5	M5	89	74	15	15	18	30	2 - 6	39,6-33,1	11,6-5,1
K1116.1206015	K1116.01206015	6	M20x1,5	M5	92	77	15	15	18	30	2 - 6	38,7-32,9	11,8-6