

# UNILOCK 5-axis reducer adapter size 80 mm

## Item description/product images



### Description

**Material:**

Body rust-free tool steel.  
Clamping bolt low carbon steel.

**Version:**

Contact faces on the body hardened and ground.  
Clamping bolt oxidised. Contact faces hardened and ground.

**Note:**

The UNILOCK 5-axis reducer adapter is suitable for clamping and positioning workpieces. Reducer adapters can be screwed onto the workpiece and mounted on the basic module or add-on module. Reducer adapters are available as hardened versions.

**On request:**

- Soft version
- Height 25 mm

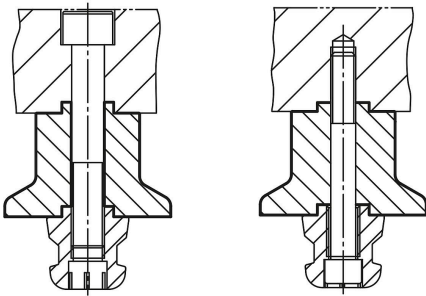

## Drawings

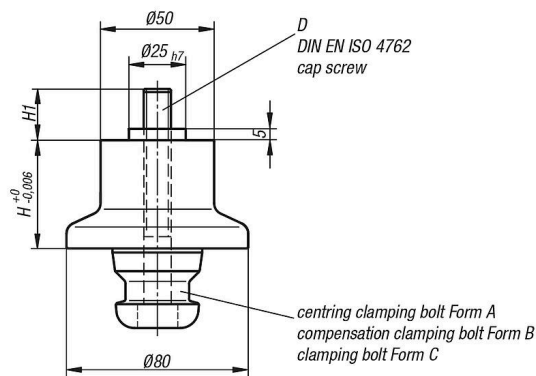

- centring clamping bolt = Form A fixes in x and y axis (reference point)
- ⊖ compensation clamping bolt = Form B fixes the free axis (bayonet pin)
- ⊕ clamping bolt = Form C clamping bolt with undersize (no centring function, clamping only)

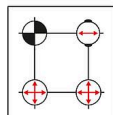

## UNILOCK 5-axis reducer adapter size 80 mm

### Overview of items

---

#### UNILOCK 5-axis reducer adapter

Order No.	Version 2	Form	Form definition	D	H	H1
K0966.501101	hard	A	centring clamping bolt	M10X100	50	25,5
K0966.502101	hard	B	compensation clamping bolt	M10X100	50	25,5
K0966.503101	hard	C	clamping bolt	M10X100	50	25,5
K0966.501121	hard	A	centring clamping bolt	M12X100	50	27,5
K0966.502121	hard	B	compensation clamping bolt	M12X100	50	27,5
K0966.503121	hard	C	clamping bolt	M12X100	50	27,5