

## UNILOCK 5-axis basic module system size 80 mm

### Item description/product images



### Description

**Material:**

Carbon steel.

**Version:**

Main body oxidised.

Contact faces hardened and ground.

**Note:**

The UNILOCK 5-axis basic module can be adapted directly to subplates with grid holes or T-slots or to tooling plates with a hole pitch of 40/50 mm system size M12. Suitable for UNILOCK zero point clamping system with UNILOCK clamping bolts. Can also be used on the conventional zero point clamping systems by mounting an appropriate adapter clamping bolt.

The following clamping forces are possible with the UNILOCK clamping bolt in conjunction with M10, M12, M16 fastening screws:

- Clamping force (M10) 35,000 N
- Clamping force (M12) 50,000 N
- Clamping force (M16) 75,000 N

Clamping force with DIN EN ISO 4762 -12.9 cap screws

Clamping bolts may only be clamped in conjunction with a mounted interchangeable unit in the clamping module.

**On request:**

With rotation lock

UNILOCK 5-axis basic module system size 80 mm

Drawings

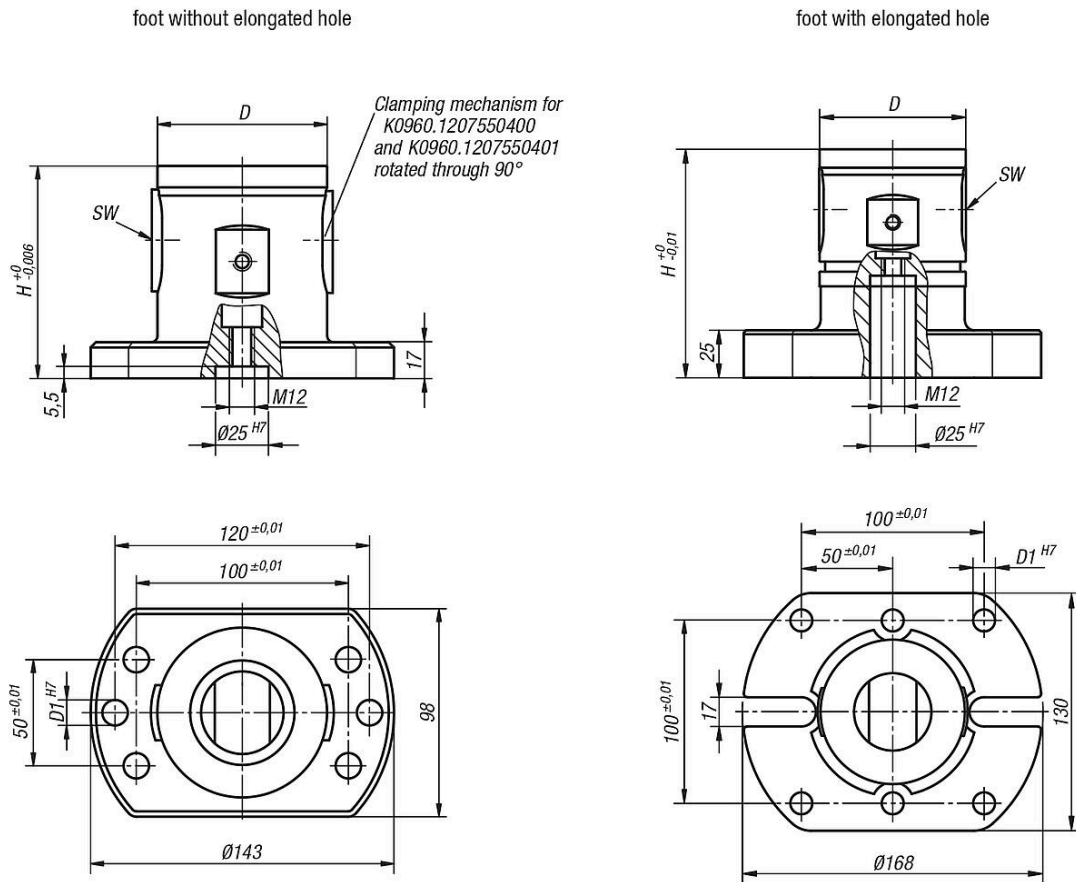

Overview of items

UNILOCK 5-axis basic module

Order No.	Version 2	Form	Form definition	H	D	D1	SW	Tightening torque max. Nm	Retraction force kN	weight kg
K0960.1207550400	foot without elongated hole	A	without rotation lock	75	80	12	6	15	15	3.64
K0960.1210050400	foot without elongated hole	A	without rotation lock	100	80	12	6	15	15	4.6
K0960.12125500	foot with elongated hole	A	without rotation lock	125	80	12	6	15	15	6.8
K0960.12150500	foot with elongated hole	A	without rotation lock	150	80	12	6	15	15	7.8
K0960.12175500	foot with elongated hole	A	without rotation lock	175	80	12	6	15	15	9.26