

Swivel hold-down clamp mini, with cam lever

Item description/product images



Description

Material:
Carbon steel.

Note:
Swing clamps are used where the clamping points must be free when the workpiece is loaded or removed.

* Admissible hand force for the handle.

Drawings

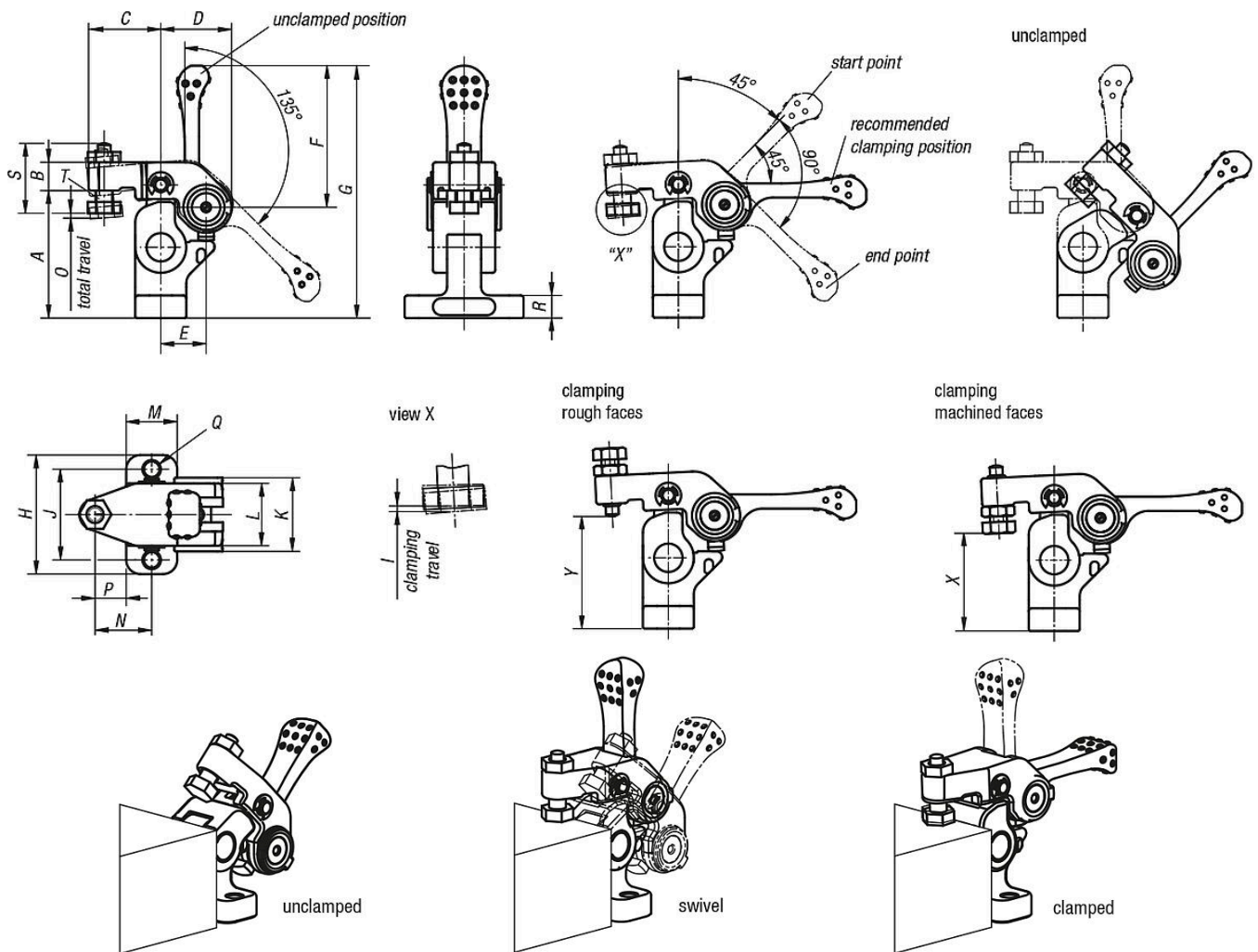

Overview of items

Swivel hold-down clamp, mini, with cam lever

Order No.	A	B	C	D	E	F	G	H	I	J	K	L	M	N	O	P	Q	R	S	T	X min.	X max.	Y min.	Y max.	F=Retaining force N	Hand force FH N
K0927.100	45	10	25,5	25	16	50	89	42	1	32	26	22	18	20	1,5	11	5,5	8	24	M6	31,5	40,5	34,5	43,5	700	100*
K0927.150	55	12	32	31	20	63	109	52	1,2	40	32	28	22	25	1,8	14	6,6	10	30,5	M8	36,4	48,6	41,4	53,6	1100	150*

Swivel hold-down clamp mini, with cam lever



Overview of items
