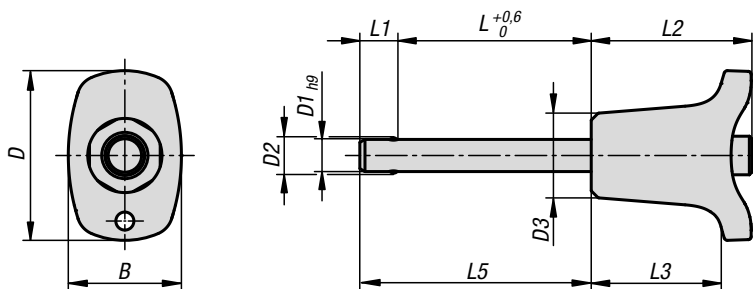

Ball lock pins

**Material:**

Grip thermoplastic.
 Push button 1.4305 stainless steel.
 Pin 1.4305 stainless steel.
 Balls 1.4125 stainless steel.
 Spring 1.4310 stainless steel wire.

Version:

Grip black grey or traffic red RAL 3020.
 Stainless steel bright.

Sample order:

K0792.002606050
 (include length L e.g. 050 for L = 50 mm.)

Note:

Ball lock pins are used for easy fastening or joining of components or workpieces.

The two balls are disengaged by pressing the push button and the pin can be slipped into holes in the workpieces. When the push button is released, the balls lock the connection securely. If required, the ball lock pins can be fitted with a retaining cable.

Shear force double shear (F) = $S \cdot \tau \cdot aB$ max.

The values given for the shear force are the theoretical breaking load.

These are non-binding reference values without consideration of safety factors and exclude any liability. The values given are for information purposes only and do not constitute a legally binding assurance of properties.

The load values have been calculated in accordance with DIN 50141. Each user must determine individually whether the ball lock pin is suitable for the respective application.

Different materials in which the ball lock pins are used, weather conditions and wear can influence the determined values.

Accessories:

Bushes for ball lock pins K0724
 Safety spiral cable K0367
 Retaining cable with loop K0367
 Key ring K0367



KIPP Ball lock pins

Order No. black	B	D	D1	D2	D3	L	L1	L2	L3	L5	Receiving hole H11	Shearing force double shear max.kN
K0792.002605***	17,6	26,4	5	5,5	13,2	10/15/20/25/30	5,9	25	20,2	15,9/20,9/25,9/30,9/35,9	5	15
K0792.002606***	17,6	26,4	6	6,85	13,2	10/15/20/25/30/35/40/45/50	6,8	25	20,2	16,8/21,8/26,8/31,8/36,8/41,8/46,8/51,8/56,8	6	22
K0792.003308***	23	33,2	8	9,5	17,3	20/25/30/35/40/45/50	7,8	33	26,1	27,8/32,8/37,8/42,8/47,8/52,8/57,8	8	38
K0792.003310***	23	33,2	10	12	17,3	20/25/30/35/40/45/50/60	8,9	33	26,1	28,9/33,9/38,9/43,9/48,9/53,9/58,9/68,9	10	60
K0792.004612***	33	45,9	12	14,5	26,3	25/30/35/40/45/50/60/70/80	9,9	39,5	31,3	34,9/39,9/44,9/49,9/54,9/59,9/69,9/79,9/89,9	12	86
K0792.004616***	33	45,9	16	19	26,3	30/35/40/45/50/60/70/80	13,1	39,5	31,3	43,1/48,1/53,1/58,1/63,1/73,1/83,1/93,1	16	153

Order No. red RAL 3020	B	D	D1	D2	D3	L	L1	L2	L3	L5	Receiving hole H11	Shearing force double shear max.kN
K0792.00842605***	17,6	26,4	5	5,5	13,2	10/15/20/25/30	5,9	25	20,2	15,9/20,9/25,9/30,9/35,9	5	15
K0792.00842606***	17,6	26,4	6	6,85	13,2	10/15/20/25/30/35/40/45/50	6,8	25	20,2	16,8/21,8/26,8/31,8/36,8/41,8/46,8/51,8/56,8	6	22
K0792.00843308***	23	33,2	8	9,5	17,3	20/25/30/35/40/45/50	7,8	33	26,1	27,8/32,8/37,8/42,8/47,8/52,8/57,8	8	38
K0792.00843310***	23	33,2	10	12	17,3	20/25/30/35/40/45/50/60	8,9	33	26,1	28,9/33,9/38,9/43,9/48,9/53,9/58,9/68,9	10	60
K0792.00844612***	33	45,9	12	14,5	26,3	25/30/35/40/45/50/60/70/80	9,9	39,5	31,3	34,9/39,9/44,9/49,9/54,9/59,9/69,9/79,9/89,9	12	86
K0792.00844616***	33	45,9	16	19	26,3	30/35/40/45/50/60/70/80	13,1	39,5	31,3	43,1/48,1/53,1/58,1/63,1/73,1/83,1/93,1	16	153

Ball lock pins

with high shear strength



Material:

Grip thermoplastic.
 Push button 1.4305 stainless steel.
 Pin 1.4542 stainless steel.
 Balls 1.4125 stainless steel.
 Spring 1.4310 stainless steel wire.

Version:

Grip black grey or traffic red RAL 3020.
 Stainless steel bright.

Sample order:

K0792.012606050
 (include length L e.g. 050 for L = 50 mm.)

Note:

Ball lock pins are used for easy fastening or joining of components.
 The two balls are disengaged by pressing the push button and the pin can be slipped into holes in the workpieces. When the push button is released, the balls lock the connection securely.

Shear force double shear (F) = S · τ aB max.

The values given for the shear force are the theoretical breaking load.
 These are non-binding reference values without consideration of safety factors and exclude any liability.
 The values given are for information purposes only and do not constitute a legally binding assurance of properties.

The load values have been calculated in accordance with DIN 50141. Each user must determine individually whether the ball lock pin is suitable for the respective application.

Different materials in which the ball lock pins are used, weather conditions and wear can influence the determined values.

Ball lock pins with high shear strength are identified by a groove marking on the pin.

Advantages:

Higher loading in comparison to standard ball lock pins.
 The pins made from 1.4542 stainless steel is hardened, has a higher shear resistance and is extremely durable.

Accessories:

Bushes for ball lock pins K0724
 Safety spiral cable K0367
 Retaining cable with loop K0367
 Key ring K0367

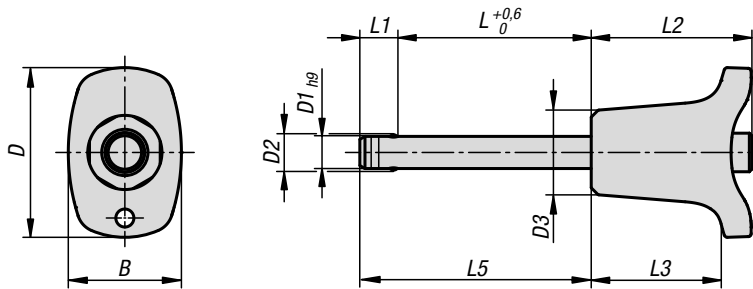

Ball lock pins

with high shear strength

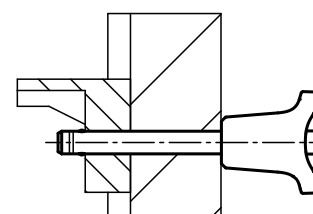

KIPP Ball lock pins with high shear strength

Order No. black	B	D	D1	D2	D3	L	L1	L2	L3	L5	Receiving hole H11	Shearing force double shear max.kN
K0792.012605***	17,6	26,4	5	5,5	13,2	10/15/20/25/30	5,9	25	20,2	15,9/20,9/25,9/30,9/35,9	5	24
K0792.012606***	17,6	26,4	6	6,85	13,2	10/15/20/25/30/35/40/45/50	6,8	25	20,2	16,8/21,8/26,8/31,8/36,8/41,8/46,8/51,8/56,8	6	35
K0792.013308***	23	33,2	8	9,5	17,3	20/25/30/35/40/45/50	7,8	33	26,1	27,8/32,8/37,8/42,8/47,8/52,8/57,8	8	63
K0792.013310***	23	33,2	10	12	17,3	20/25/30/35/40/45/50/60	8,9	33	26,1	28,9/33,9/38,9/43,9/48,9/53,9/58,9/68,9	10	100
K0792.014612***	33	45,9	12	14,5	26,3	25/30/35/40/45/50/60/70/80	9,9	39,5	31,3	34,9/39,9/44,9/49,9/54,9/59,9/69,9/79,9/89,9	12	144
K0792.014616***	33	45,9	16	19	26,3	30/35/40/45/50/60/70/80	13,1	39,5	31,3	43,1/48,1/53,1/58,1/63,1/73,1/83,1/93,1	16	257

Order No. red RAL 3020	B	D	D1	D2	D3	L	L1	L2	L3	L5	Receiving hole H11	Shearing force double shear max.kN
K0792.01842605***	17,6	26,4	5	5,5	13,2	10/15/20/25/30	5,9	25	20,2	15,9/20,9/25,9/30,9/35,9	5	24
K0792.01842606***	17,6	26,4	6	6,85	13,2	10/15/20/25/30/35/40/45/50	6,8	25	20,2	16,8/21,8/26,8/31,8/36,8/41,8/46,8/51,8/56,8	6	35
K0792.01843308***	23	33,2	8	9,5	17,3	20/25/30/35/40/45/50	7,8	33	26,1	27,8/32,8/37,8/42,8/47,8/52,8/57,8	8	63
K0792.01843310***	23	33,2	10	12	17,3	20/25/30/35/40/45/50/60	8,9	33	26,1	28,9/33,9/38,9/43,9/48,9/53,9/58,9/68,9	10	100
K0792.01844612***	33	45,9	12	14,5	26,3	25/30/35/40/45/50/60/70/80	9,9	39,5	31,3	34,9/39,9/44,9/49,9/54,9/59,9/69,9/79,9/89,9	12	144
K0792.01844616***	33	45,9	16	19	26,3	30/35/40/45/50/60/70/80	13,1	39,5	31,3	43,1/48,1/53,1/58,1/63,1/73,1/83,1/93,1	16	257

Ball lock pins

with T-grip

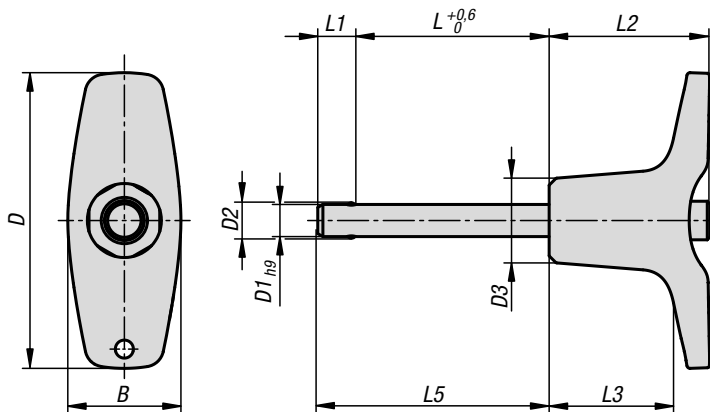

Material:

Grip thermoplastic.
 Push button 1.4305 stainless steel.
 Pin 1.4305 stainless steel.
 Balls 1.4125 stainless steel.
 Spring 1.4310 stainless steel wire.

Version:

Grip black grey or traffic red RAL 3020.
 Stainless steel bright.

Sample order:

K0792.204606050
 (include length L e.g. 050 for L = 50 mm.)

Note:

Ball lock pins are used for easy fastening or joining of components or workpieces.

The two balls are disengaged by pressing the push button and the pin can be slipped into holes in the workpieces. When the push button is released, the balls lock the connection securely. If required, the ball lock pins can be fitted with a retaining cable.

Shear force double shear (F) = S · τ aB max.

The values given for the shear force are the theoretical breaking load.

These are non-binding reference values without consideration of safety factors and exclude any liability. The values given are for information purposes only and do not constitute a legally binding assurance of properties.

The load values have been calculated in accordance with DIN 50141. Each user must determine individually whether the ball lock pin is suitable for the respective application.

Different materials in which the ball lock pins are used, weather conditions and wear can influence the determined values.

Accessories:

Bushes for ball lock pins K0724
 Safety spiral cable K0367
 Retaining cable with loop K0367
 Key ring K0367

Ball lock pins

with T-grip



KIPP Ball lock pins with T-grip

Order No. black	B	D	D1	D2	D3	L	L1	L2	L3	L5	Receiving hole H11	Shearing force double shear max.kN
K0792.204605***	17,6	46	5	5,5	13,2	10/15/20/25/30	5,9	25	19,4	15,9/20,9/25,9/30,9/35,9	5	15
K0792.204606***	17,6	46	6	6,85	13,2	10/15/20/25/30/35/40/45/50	6,8	25	19,4	16,8/21,8/26,8/31,8/36,8/41,8/46,8/51,8/56,8	6	22
K0792.206308***	23	62,9	8	9,5	17,3	20/25/30/35/40/45/50	7,8	33	24,4	27,8/32,8/37,8/42,8/47,8/52,8/57,8	8	38
K0792.206310***	23	62,9	10	12	17,3	20/25/30/35/40/45/50/60	8,9	33	24,4	28,9/33,9/38,9/43,9/48,9/53,9/58,9/68,9	10	60
K0792.208212***	33	81,8	12	14,5	26,3	25/30/35/40/45/50/60/70/80	9,9	39,5	28,8	34,9/39,9/44,9/49,9/54,9/59,9/69,9/79,9/89,9	12	86
K0792.208216***	33	81,8	16	19	26,3	30/35/40/45/50/60/70/80	13,1	39,5	28,8	43,1/48,1/53,1/58,1/63,1/73,1/83,1/93,1	16	153

Order No. red RAL 3020	B	D	D1	D2	D3	L	L1	L2	L3	L5	Receiving hole H11	Shearing force double shear max.kN
K0792.20844605***	17,6	46	5	5,5	13,2	10/15/20/25/30	5,9	25	19,4	15,9/20,9/25,9/30,9/35,9	5	15
K0792.20844606***	17,6	46	6	6,85	13,2	10/15/20/25/30/35/40/45/50	6,8	25	19,4	16,8/21,8/26,8/31,8/36,8/41,8/46,8/51,8/56,8	6	22
K0792.20846308***	23	62,9	8	9,5	17,3	20/25/30/35/40/45/50	7,8	33	24,4	27,8/32,8/37,8/42,8/47,8/52,8/57,8	8	38
K0792.20846310***	23	62,9	10	12	17,3	20/25/30/35/40/45/50/60	8,9	33	24,4	28,9/33,9/38,9/44,9/48,9/54,9/58,9/68,9	10	60
K0792.20848212***	33	81,8	12	14,5	26,3	25/30/35/40/45/50/60/70/80	9,9	39,5	28,8	34,9/39,9/44,9/49,9/54,9/59,9/69,9/79,9/89,9	12	86
K0792.20848216***	33	81,8	16	19	26,3	30/35/40/45/50/60/70/80	13,1	39,5	28,8	43,1/48,1/53,1/58,1/63,1/73,1/83,1/93,1	16	153

Ball lock pins with T-grip

with high shear strength



Material:

Grip thermoplastic.
Push button 1.4305 stainless steel.
Pin 1.4542 stainless steel.
Balls 1.4125 stainless steel.
Spring 1.4310 stainless steel wire.

Version:

Grip black grey or traffic red RAL 3020.
Stainless steel bright.

Sample order:

K0792.214606050
(include length L e.g. 050 for L = 50 mm.)

Note:

Ball lock pins are used for easy fastening or joining of components.
The two balls are disengaged by pressing the push button and the pin can be slipped into holes in the workpieces. When the push button is released, the balls lock the connection securely.

Shear force double shear (F) = S · τ aB max.

The values given for the shear force are the theoretical breaking load.
These are non-binding reference values without consideration of safety factors and exclude any liability.
The values given are for information purposes only and do not constitute a legally binding assurance of properties.

The load values have been calculated in accordance with DIN 50141. Each user must determine individually whether the ball lock pin is suitable for the respective application.

Different materials in which the ball lock pins are used, weather conditions and wear can influence the determined values.

Ball lock pins with high shear strength are identified by a groove marking on the pin.

Advantages:

Higher loading in comparison to standard ball lock pins.
The pins made from 1.4542 stainless steel is hardened, has a higher shear resistance and is extremely durable.

Accessories:

Bushes for ball lock pins K0724
Safety spiral cable K0367
Retaining cable with loop K0367
Key ring K0367

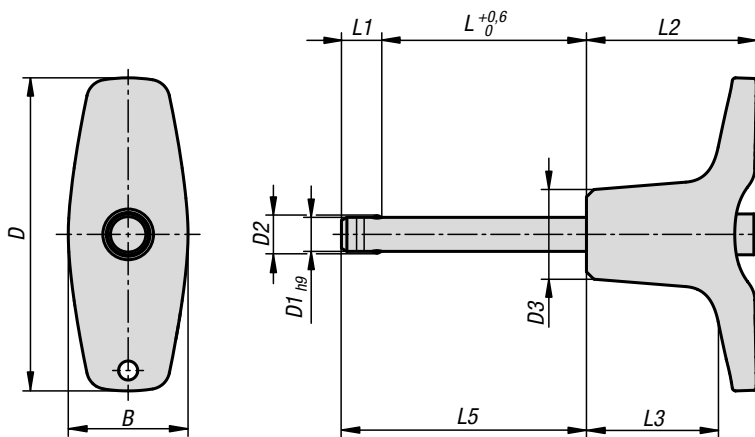

Ball lock pins with T-grip

with high shear strength

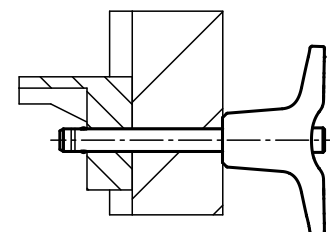

KIPP Ball lock pins with T-grip with high shear strength

Order No. black	B	D	D1	D2	D3	L	L1	L2	L3	L5	Receiving hole H11	Shearing force double shear max.kN
K0792.214605***	17,6	46	5	5,5	13,2	10/15/20/25/30	5,9	25	19,4	15,9/20,9/25,9/30,9/35,9	5	24
K0792.214606***	17,6	46	6	6,85	13,2	10/15/20/25/30/35/40/45/50	6,8	25	19,4	16,8/21,8/26,8/31,8/36,8/41,8/46,8/51,8/56,8	6	35
K0792.216308***	23	62,9	8	9,5	17,3	20/25/30/35/40/45/50	7,8	33	24,4	27,8/32,8/37,8/42,8/47,8/52,8/57,8	8	63
K0792.216310***	23	62,9	10	12	17,3	20/25/30/35/40/45/50/60	8,9	33	24,4	28,9/33,9/38,9/43,9/48,9/53,9/58,9/68,9	10	100
K0792.218212***	33	81,8	12	14,5	26,3	25/30/35/40/45/50/60/70/80	9,9	39,5	28,8	34,9/39,9/44,9/49,9/54,9/59,9/69,9/79,9/89,9	12	144
K0792.218216***	33	81,8	16	19	26,3	30/35/40/45/50/60/70/80	13,1	39,5	28,8	43,1/48,1/53,1/58,1/63,1/73,1/83,1/93,1	16	257

Order No. red RAL 3020	B	D	D1	D2	D3	L	L1	L2	L3	L5	Receiving hole H11	Shearing force double shear max.kN
K0792.21844605***	17,6	46	5	5,5	13,2	10/15/20/25/30	5,9	25	19,4	15,9/20,9/25,9/30,9/35,9	5	24
K0792.21844606***	17,6	46	6	6,85	13,2	10/15/20/25/30/35/40/45/50	6,8	25	19,4	16,8/21,8/26,8/31,8/36,8/41,8/46,8/51,8/56,8	6	35
K0792.21846308***	23	62,9	8	9,5	17,3	20/25/30/35/40/45/50	7,8	33	24,4	27,8/32,8/37,8/42,8/47,8/52,8/57,8	8	63
K0792.21846310***	23	62,9	10	12	17,3	20/25/30/35/40/45/50/60	8,9	33	24,4	28,9/33,9/38,9/43,9/48,9/53,9/58,9/68,9	10	100
K0792.21848212***	33	81,8	12	14,5	26,3	25/30/35/40/45/50/60/70/80	9,9	39,5	28,8	34,9/39,9/44,9/49,9/54,9/59,9/69,9/79,9/89,9	12	144
K0792.21848216***	33	81,8	16	19	26,3	30/35/40/45/50/60/70/80	13,1	39,5	28,8	43,1/48,1/53,1/58,1/63,1/73,1/83,1/93,1	16	257

Ball lock pins

with L-grip

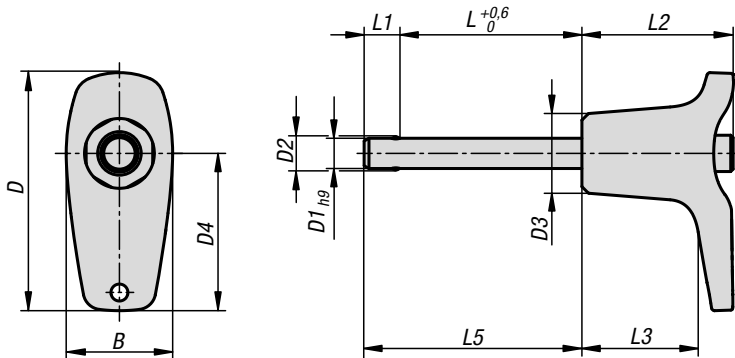

Material:

Grip thermoplastic.
 Push button 1.4305 stainless steel.
 Pin 1.4305 stainless steel.
 Balls 1.4125 stainless steel.
 Spring 1.4310 stainless steel wire.

Version:

Grip black grey or traffic red RAL 3020.
 Stainless steel bright.

Sample order:

K0792.102606050
 (include length L e.g. 050 for L = 50 mm.)

Note:

Ball lock pins are used for easy fastening or joining of components or workpieces.

The two balls are disengaged by pressing the push button and the pin can be slipped into holes in the workpieces. When the push button is released, the balls lock the connection securely. If required, the ball lock pins can be fitted with a retaining cable.

Shear force double shear (F) = $S \cdot \tau \cdot aB$ max.

The values given for the shear force are the theoretical breaking load.

These are non-binding reference values without consideration of safety factors and exclude any liability. The values given are for information purposes only and do not constitute a legally binding assurance of properties.

The load values have been calculated in accordance with DIN 50141. Each user must determine individually whether the ball lock pin is suitable for the respective application.

Different materials in which the ball lock pins are used, weather conditions and wear can influence the determined values.

Accessories:

Bushes for ball lock pins K0724
 Safety spiral cable K0367
 Retaining cable with loop K0367
 Key ring K0367

Ball lock pins

with L-grip



KIPP Ball lock pins with L-grip

Order No. black	B	D	D1	D2	D3	D4	L	L1	L2	L3	L5	Receiving hole H11	Shearing force double shear max.kN
K0792.102605***	17,6	39,3	5	5,5	13,2	26	10/15/20/25/30	5,9	25	19,2	15,9/20,9/25,9/30,9/35,9	5	15
K0792.102606***	17,6	39,3	6	6,85	13,2	26	10/15/20/25/30/35/40/45/50	6,8	25	19,2	16,8/21,8/26,8/31,8/36,8/41,8/46,8/51,8/56,8	6	22
K0792.103508***	23	52,2	8	9,5	17,3	35,4	20/25/30/35/40/45/50	7,8	33	24,2	27,8/32,8/37,8/42,8/47,8/52,8/57,8	8	38
K0792.103510***	23	52,2	10	12	17,3	35,4	20/25/30/35/40/45/50/60	8,9	33	24,2	28,9/33,9/38,9/43,9/48,9/53,9/58,9/68,9	10	60
K0792.104712***	33	70,2	12	14,5	26,3	47	25/30/35/40/45/50/60/70/80	9,9	39,5	28,4	34,9/39,9/44,9/49,9/54,9/59,9/69,9/79,9/89,9	12	86
K0792.104716***	33	70,2	16	19	26,3	47	30/35/40/45/50/60/70/80	13,1	39,5	28,4	43,1/48,1/53,1/58,1/63,1/73,1/83,1/93,1	16	153

Order No. red RAL 3020	B	D	D1	D2	D3	D4	L	L1	L2	L3	L5	Receiving hole H11	Shearing force double shear max.kN
K0792.10842605***	17,6	39,3	5	5,5	13,2	26	10/15/20/25/30	5,9	25	19,2	15,9/20,9/25,9/30,9/35,9	5	15
K0792.10842606***	17,6	39,3	6	6,85	13,2	26	10/15/20/25/30/35/40/45/50	6,8	25	19,2	16,8/21,8/26,8/31,8/36,8/41,8/46,8/51,8/56,8	6	22
K0792.10843508***	23	52,2	8	9,5	17,3	35,4	20/25/30/35/40/45/50	7,8	33	24,2	27,8/32,8/37,8/42,8/47,8/52,8/57,8	8	38
K0792.10843510***	23	52,2	10	12	17,3	35,4	20/25/30/35/40/45/50/60	8,9	33	24,2	28,9/33,9/38,9/43,9/48,9/53,9/58,9/68,9	10	60
K0792.10844712***	33	70,2	12	14,5	26,3	47	25/30/35/40/45/50/60/70/80	9,9	39,5	28,4	34,9/39,9/44,9/49,9/54,9/59,9/69,9/79,9/89,9	12	86
K0792.10844716***	33	70,2	16	19	26,3	47	30/35/40/45/50/60/70/80	13,1	39,5	28,4	43,1/48,1/53,1/58,1/63,1/73,1/83,1/93,1	16	153

Ball lock pins with L-grip

with high shear strength

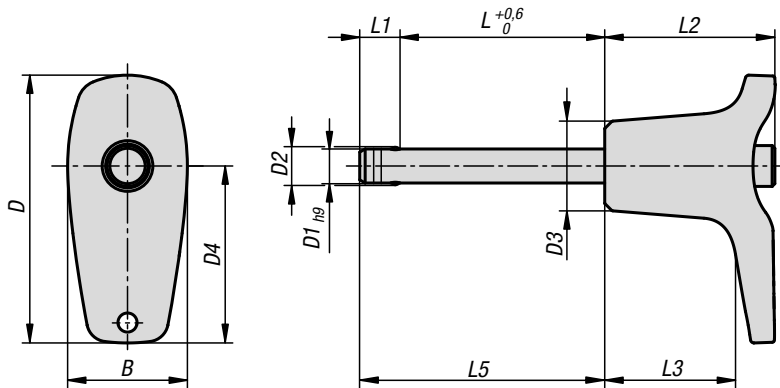

Material:

Grip thermoplastic.
Push button 1.4305 stainless steel.
Pin 1.4542 stainless steel.
Balls 1.4125 stainless steel.
Spring 1.4310 stainless steel wire.

Version:

Grip black grey or traffic red RAL 3020.
Stainless steel bright.

Sample order:

K0792.112606050
(include length L e.g. 050 for L = 50 mm.)

Note:

Ball lock pins are used for easy fastening or joining of components.

The two balls are disengaged by pressing the push button and the pin can be slipped into holes in the workpieces. When the push button is released, the balls lock the connection securely.

Shear force double shear (F) = S · τ aB max.

The values given for the shear force are the theoretical breaking load.

These are non-binding reference values without consideration of safety factors and exclude any liability. The values given are for information purposes only and do not constitute a legally binding assurance of properties.

The load values have been calculated in accordance with DIN 50141. Each user must determine individually whether the ball lock pin is suitable for the respective application.

Different materials in which the ball lock pins are used, weather conditions and wear can influence the determined values.

Ball lock pins with high shear strength are identified by a groove marking on the pin.

Advantages:

Higher loading in comparison to standard ball lock pins.

The pins made from 1.4542 stainless steel is hardened, has a higher shear resistance and is extremely durable.

Accessories:

Bushes for ball lock pins K0724
Safety spiral cable K0367
Retaining cable with loop K0367
Key ring K0367

Ball lock pins with L-grip

with high shear strength

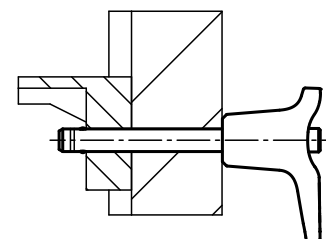

KIPP Ball lock pins with L-grip with high shear strength

Order No. black	B	D	D1	D2	D3	D4	L	L1	L2	L3	L5	Receiving hole H11	Shearing force double shear max.kN
K0792.112605***	17,6	39,3	5	5,5	13,2	26	10/15/20/25/30	5,9	25	19,2	15,9/20,9/25,9/30,9/35,9	5	24
K0792.112606***	17,6	39,3	6	6,85	13,2	26	10/15/20/25/30/35/40/45/50	6,8	25	19,2	16,8/21,8/26,8/31,8/36,8/41,8/46,8/51,8/56,8	6	35
K0792.113508***	23	52,2	8	9,5	17,3	35,4	20/25/30/35/40/45/50	7,8	33	24,2	27,8/32,8/37,8/42,8/47,8/52,8/57,8	8	63
K0792.113510***	23	52,2	10	12	17,3	35,4	20/25/30/35/40/45/50/60	8,9	33	24,2	28,9/33,9/38,9/43,9/48,9/53,9/58,9/68,9	10	100
K0792.114712***	33	70,2	12	14,5	26,3	47	25/30/35/40/45/50/60/70/80	9,9	39,5	28,4	34,9/39,9/44,9/49,9/54,9/59,9/69,9/79,9/89,9	12	144
K0792.114716***	33	70,2	16	19	26,3	47	30/35/40/45/50/60/70/80	13,1	39,5	28,4	43,1/48,1/53,1/58,1/63,1/73,1/83,1/93,1	16	257

Order No. red RAL 3020	B	D	D1	D2	D3	D4	L	L1	L2	L3	L5	Receiving hole H11	Shearing force double shear max.kN
K0792.11842605***	17,6	39,3	5	5,5	13,2	26	10/15/20/25/30	5,9	25	19,2	15,9/20,9/25,9/30,9/35,9	5	24
K0792.11842606***	17,6	39,3	6	6,85	13,2	26	10/15/20/25/30/35/40/45/50	6,8	25	19,2	16,8/21,8/26,8/31,8/36,8/41,8/46,8/51,8/56,8	6	35
K0792.11843508***	23	52,2	8	9,5	17,3	35,4	20/25/30/35/40/45/50	7,8	33	24,2	27,8/32,8/37,8/42,8/47,8/52,8/57,8	8	63
K0792.11843510***	23	52,2	10	12	17,3	35,4	20/25/30/35/40/45/50/60	8,9	33	24,2	28,9/33,9/38,9/43,9/48,9/53,9/58,9/68,9	10	100
K0792.11844712***	33	70,2	12	14,5	26,3	47	25/30/35/40/45/50/60/70/80	9,9	39,5	28,4	34,9/39,9/44,9/49,9/54,9/59,9/69,9/79,9/89,9	12	144
K0792.11844716***	33	70,2	16	19	26,3	47	30/35/40/45/50/60/70/80	13,1	39,5	28,4	43,1/48,1/53,1/58,1/63,1/73,1/83,1/93,1	16	257