

Ball transfer units

with steel housing

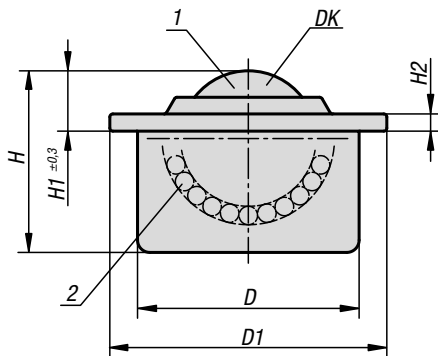

Material:

Electro zinc-plated steel or stainless steel.

Sample order:

K0760.122

Note:

Ball transfer units with steel housing have a felt seal to protect against dirt. K0760-115 has no felt seal.

Drawing reference:

- 1) load ball
- 2) bearing balls

Form B: cap and housing electro zinc-plated, balls steel

Form C: cap and housing electro zinc-plated, balls stainless steel

Form D: cap, housing and balls stainless steel

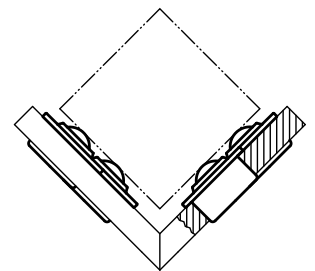
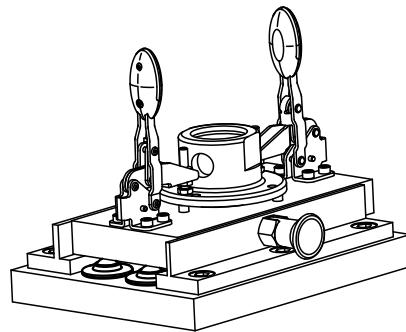

KIPP Ball transfer units with steel housing

Order No.	Form	DK	D	D1	H	H1	H2	Load rating C (N)	Suitable tolerance ring
K0760.115	B	15,8	24±0,065	31	21	9,5	2,8	600	K0766.024
K0760.122	B	22,2	36±0,080	45	30	9,8	2,8	1600	K0766.036
K0760.130	B	30	45±0,080	55	37	13,8	4	3000	K0766.045
K0760.145	B	44,5	62±0,095	75	53,5	19	4	6100	K0766.062
K0760.215	C	15,8	24±0,065	31	21	9,5	2,8	600	K0766.024
K0760.222	C	22,2	36±0,080	45	30	9,8	2,8	1600	K0766.036
K0760.230	C	30	45±0,080	55	37	13,8	4	3000	K0766.045
K0760.245	C	44,5	62±0,095	75	53,5	19	4	6100	K0766.062
K0760.315	D	15,8	24±0,065	31	21	9,5	2,8	380	K0766.024
K0760.322	D	22,2	36±0,080	45	30	9,8	2,8	1000	K0766.036
K0760.330	D	30	45±0,080	55	37	13,8	4	2000	K0766.045