

## Rod ends with ball bearing

internal thread, DIN ISO 12240-4

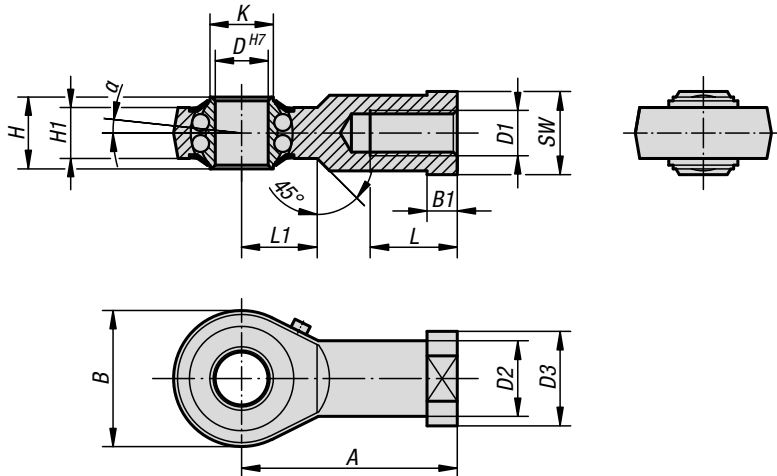

**Material:**

Casing drop-forged steel, tempered.

**Version:**

Electro zinc-plated.

Bearing play 15 - 40 µm.

**Sample order:**

K0717.16

**Note:**

The hardened ball bearing is long-term greased and sealed with cover washers. The connection dimensions comply with DIN 648 Form Series KA.

Up to D = 10 the rod ends have a DIN 3405/A flush type grease nipple.

From D = 12 they have a DIN 71412/A conical head type grease nipple.

### KIPP Rod ends with ball bearing, internal thread, DIN ISO 12240-4

Order No. RH thread	Order No. LH thread	D	D1	D2	D3	A	B	B1	H	H1	K	L	L1	SW	α	Dynamic load rating N	Static load rating N	Rev. limit n max. rpm
K0717.06	K0717.061	6	M6	10	13	30	20	5	9	6,75	9	12	10	11	8°	2750	650	1350
K0717.08	K0717.081	8	M8	12,5	16	36	24	5	12	9	10,5	16	12	14	8,5°	4000	1000	1300
K0717.10	K0717.101	10	M10	15	19	43	28	6,5	14	10,5	12	20	15	17	8°	4450	1450	1225
K0717.12	K0717.121	12	M12	17,5	22	50	32	6,5	16	12	14,5	22	16	19	7,5°	4950	1800	1125
K0717.16	K0717.161	16	M16	22	27	64	42	8	21	15	19	28	22	22	8°	6250	2350	975
K0717.20	K0717.201	20	M20x1,5	27,5	34	77	50	10	25	18	24,5	33	26	30	7°	7900	3450	825
K0717.22	K0717.221	22	M22x1,5	30	38	84	54	12	28	20	26	37	26	32	8°	9300	3980	725