

Rod ends with ball bearing

external thread, DIN ISO 12240-4

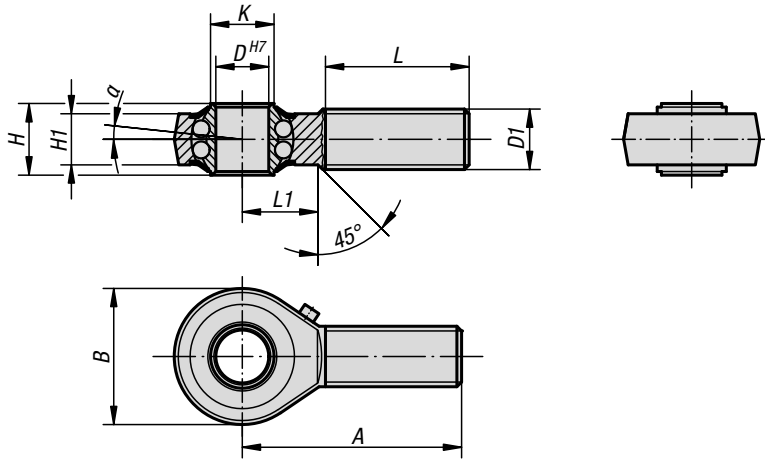

Material:

Casing drop-forged steel, tempered.

Version:

Electro zinc-plated.

Bearing play 15 - 40 µm.

Sample order:

K0716.12

Note:

The hardened ball bearing is long-term greased and sealed with cover washers. The connection dimensions comply with DIN 648 series KA.

Rod ends are primarily used where movement processes are transmitted and there is no exact alignment.

Up to D = 10 the rod ends have a DIN 3405/A flush type grease nipple.

From D = 12 they have a DIN 71412/A conical head type grease nipple.

KIPP Rod ends with ball bearing, external thread, DIN ISO 12240-4

Order No. RH thread	Order No. LH thread	D	D1	A	B	H	H1	K	L	L1	α	Dynamic load rating N	Static load rating N	Rev. limit n max. rpm
K0716.06	K0716.061	6	M6	36	20	9	6,75	9	22	12	8°	2750	650	1350
K0716.08	K0716.081	8	M8	42	24	12	9	10,5	25	15	8,5°	4000	1000	1300
K0716.10	K0716.101	10	M10	48	28	14	10,5	12	29	15	8°	4450	1450	1225
K0716.12	K0716.121	12	M12	54	32	16	12	14,5	33	19	7,5°	4950	1800	1125
K0716.16	K0716.161	16	M16	66	42	21	15	19	40	22	8°	6250	2350	975
K0716.20	K0716.201	20	M20x1,5	78	50	25	18	24,5	47	28	7°	7900	3450	825
K0716.22	K0716.221	22	M22x1,5	84	54	28	20	26	51	26	8°	9300	3980	725