

Levelling feet plates with rubber base

steel or stainless steel



Material:

Plate steel or stainless steel 1.4301.
Rubber base NBR, Shore 70A.

Version:

Steel chromed.
Stainless steel polished.

Sample order:

K0673.10801
K0673.10801 and K0669.080501 **assembled**

Note for ordering:

If the levelling foot plate and the threaded spindle are to be supplied assembled, please add the suffix **“assembled”** to the order number for the plate and spindle (e.g. K0673.10801 and K0669.080501 **assembled**).

Note:

Levelling feet consist of a plate and a threaded spindle. Any plate can be combined with any threaded spindle. For matching threaded spindles see K0669.

Drawing reference:

1) X with spindle size:

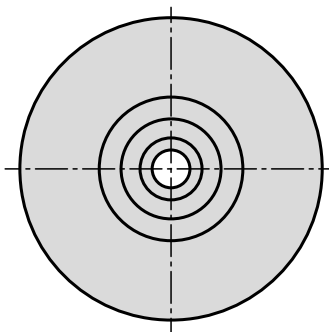
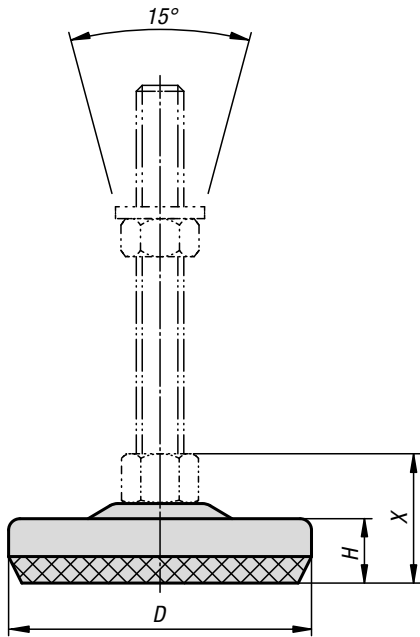

D = 80 :

- ① M8/M10 = 37 mm
- M12 = 38 mm
- M16 = 42 mm
- M20 = 45 mm

D = 100 :

- ① M8/M10 = 39 mm
- M12 = 40 mm
- M16 = 44 mm
- M20 = 47 mm

KIPP Levelling feet plates with rubber base steel or stainless steel

Order No. steel	Order No. stainless steel	D	H	Load rating max. kN
K0673.10801	K0673.10802	80	17	8,5
K0673.11001	K0673.11002	100	19	20