

Wedge clamps

machinable



Material:

Wedge and jaw segments carbon steel.

Version:

Wedge and jaw segments tempered, black.

Sample order:

K0649.3110

Note:

The special feature of these wedge clamps is the machinable jaws. This extra material enables the jaws to be machined to suit the geometry of the workpiece. In addition, the functioning principle makes them suitable for series clamping. The wedge shape creates high clamping forces.

The wedge clamps can be mounted in tapped holes or T-slots. Tightening the clamping screw moves the two clamping segments outwards and press the workpieces against the fixed jaws of the machining fixture.

The wedge has a slightly elongated hole allowing for movement to compensate for tolerances.

Spread width:

M8 = ±0.5 mm

M10 = ±1.0 mm

M12 = ±1.0 mm

M16 = ±1.5 mm

Attention:

These wedge clamps have a machining allowance per jaw of 3 mm for version M8 and 5 mm for versions M10, M12 and M16.

Drawing reference:

D) DIN 6912 cap screw

- 1) wedge clamps
- 2) workpiece
- 3) fixed stop
- 4) base plate
- 5) hydraulic/pneumatic cylinder

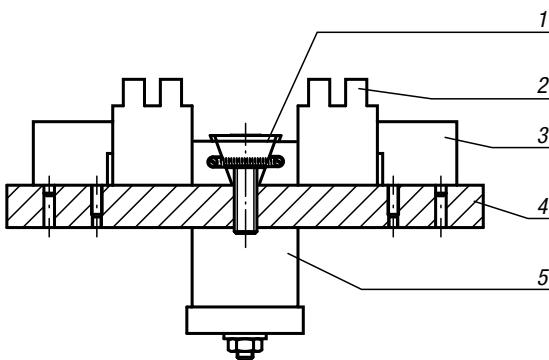
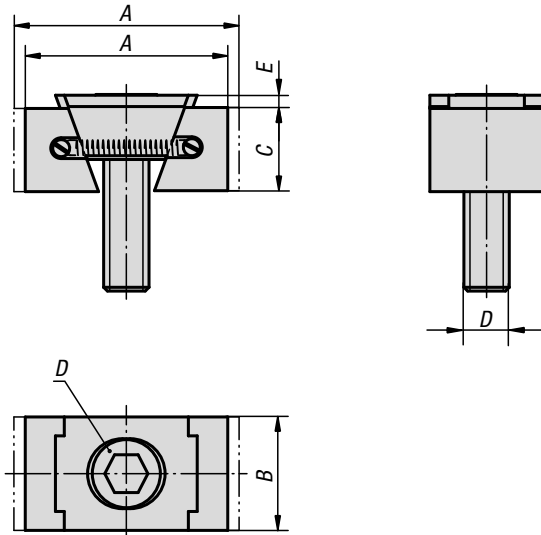

KIPP Wedge clamps, machinable

Order No.	Version	A min.	A max.	B	C	D	E	Clamping force max. kN	Tightening torque max. Nm
K0649.3108	narrow	36,5	39,5	24	15	M8X25	2	11	19
K0649.3110	narrow	42	47	28	19	M10X25	3,5	15	37
K0649.3112	narrow	54	59,5	30	22	M12X40	3,5	23	65
K0649.3116	narrow	65	72	40	29	M16X60	4	38	160
K0649.3208	wide	36,5	39,5	30	15	M8X25	2	11	19
K0649.3210	wide	42	47	38	19	M10X25	3,5	15	37
K0649.3212	wide	54	59,5	48	22	M12X40	3,5	23	65
K0649.3216	wide	65	72	48	29	M16X60	4	38	160