

Centring clamps

with ball or hexagon segments



Material:

Body 1.2842.
Ball and hex segments 1.4112.
Tension spring 1.4310.

Version:

Body hardened and black oxidised.
Ball and hex segments hardened and ground.

Sample order:

K0644.0101203

Application:

For centre positioning and clamping in blind holes.
Operated from below, manual or automatic using pneumatics or hydraulics.

Advantages:

- Precise self-centring.
- Distortion free clamping.
- Large spread range.
- Low overall height.
- Positive down force.

Technical data:

Repetitive accuracy ± 0.025
Concentric accuracy ± 0.05

Drawing reference:

Form A:

With balls for holes where light marking is acceptable.

Form B:

With hexagons for sensitive hole surfaces.

1) Mounting aid:

pin to accurately position the mandrel segments.

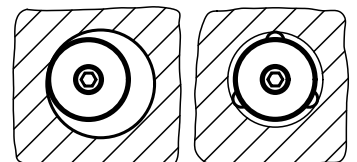
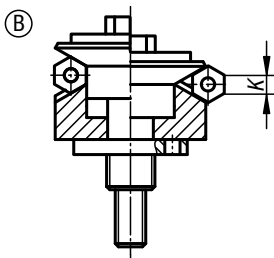
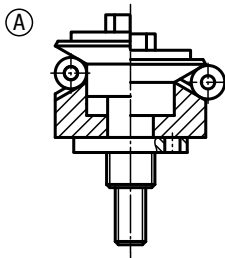
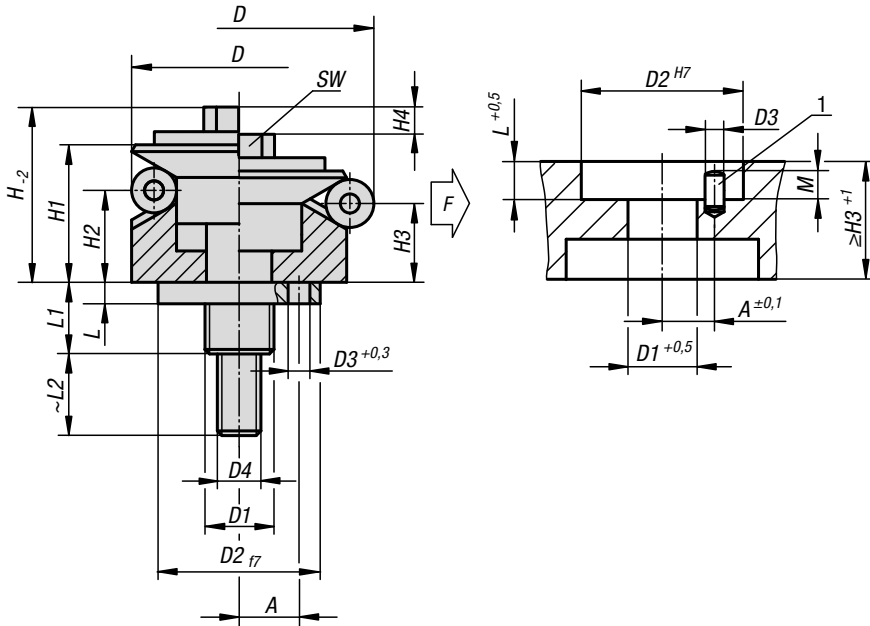

Centring clamps

with ball or hexagon segments

KIPP Centring clamps with ball segments

Order No.	Form	A	D min.	D max.	D1	D2	D3	D4	H	H1	H2	H3	H4	L	L1	L2	M	SW	Ball Ø	No. of balls	Clamping force max. kN	Tightening torque max. Nm
K0644.0101203	A	3,5	11,7	14,2	M5	10	1,5	M3	12,8	10	4,2	3	1,4	3,5	11	10	2	5,5	2,5	3	0,5	2
K0644.0101503	A	4,5	14,5	18,5	M6	12	2	M3	17,3	14,5	9,8	8,6	2,3	5,5	14,1	12	2,5	5,5	4	3	3,5	2
K0644.0101904	A	5,5	18,5	22,5	M8	15	2,5	M4	20,9	16,5	11,6	10,4	2,3	7,5	18,2	14	3,5	7	4	3	4	5
K0644.0102305	A	7	22,5	26,5	M10	20	3	M5	25,4	19,8	14,2	13	2,3	6	17,4	15	3,5	8	4	3	4,5	10
K0644.0102705	A	7	26,5	30,5	M10	20	3	M5	25,4	19,8	14,2	13	2,3	6	17,4	15	3,5	8	4	3	4,5	10
K0644.0103106	A	9	30,5	38,5	M12	25	4	M6	30,3	23,1	14,2	11,9	4,6	7	21,9	20	3,5	10	8	3	4,5	17
K0644.0103906	A	11	38,5	46,5	M12	30	4	M6	34,2	27,2	17,8	15,5	4,6	7,5	22,5	20	4,5	10	8	6	6,5	17
K0644.0104706	A	11	46,5	54,5	M12	30	4	M6	34,2	27,2	18	15,7	4,6	7,5	22,5	20	6,5	10	8	6	6,5	17
K0644.0105508	A	15	54,5	70,5	M14x1,5	45	5	M8	49,9	40,6	23,7	19,1	9,3	9	24,5	32	6,5	13	16	6	8	43
K0644.0107108	A	17	70,5	86,5	M16x1,5	60	5	M8	55,4	46,1	28,3	23,7	9,3	10	29,4	20	6,5	13	16	6	10	43
K0644.0108708	A	25	86,5	102,5	M16x1,5	60	5	M10	61,6	51	30,2	25,7	9,3	10	29,4	25	6,5	17	16	6	12,5	79

KIPP Centring clamps with hexagon segments

Order No.	Form	A	D min.	D max.	D1	D2	D3	D4	H	H1	H2	H3	H4	L	L1	L2	M	K	SW	No. of hex	Clamping force max. kN	Tightening torque max. Nm
K0644.0201503	B	4,5	14,5	18,5	M6	12	2	M3	17,3	14,5	9,8	8,6	1,4	5,5	14,1	12	2,5	4	5,5	3	3,5	2
K0644.0201904	B	5,5	18,5	22,5	M8	15	2,5	M4	20,9	16,5	11,6	10,4	2,3	7,5	18,2	14	3,5	4	7	3	4	5
K0644.0202305	B	7	22,5	26,5	M10	20	3	M5	25,4	19,8	14,2	13	2,3	6	17,4	15	3,5	4	8	3	4,5	10
K0644.0202705	B	7	26,5	30,5	M10	20	3	M5	25,4	19,8	14,2	13	2,3	6	17,4	15	3,5	4	8	3	4,5	10
K0644.0203106	B	9	30,5	38,5	M12	25	4	M6	30,3	23,1	14,2	11,9	4,6	7	21,9	20	3,5	8	10	6	4,5	17
K0644.0203906	B	11	38,5	46,5	M12	30	4	M6	34,2	27,2	17,8	15,5	4,6	7,5	22,5	20	4,5	8	10	6	6,5	17
K0644.0204706	B	11	46,5	54,5	M12	30	4	M6	34,2	27,2	18	15,7	4,6	7,5	22,5	20	6,5	8	10	6	6,5	17
K0644.0205508	B	15	54,5	70,5	M14	45	5	M8	49,9	40,6	23,7	19,1	9,3	9	24,5	32	6,5	16	13	6	8	43
K0644.0207108	B	17	70,5	86,5	M16	60	5	M8	55,4	46,1	28,3	23,7	9,3	10	29,4	20	6,5	16	13	6	10	43
K0644.0208708	B	25	86,5	102,5	M16	60	5	M10	61,6	51	30,2	25,7	9,3	10	29,4	25	6,5	16	16	6	12,5	79