

Caps for filler necks

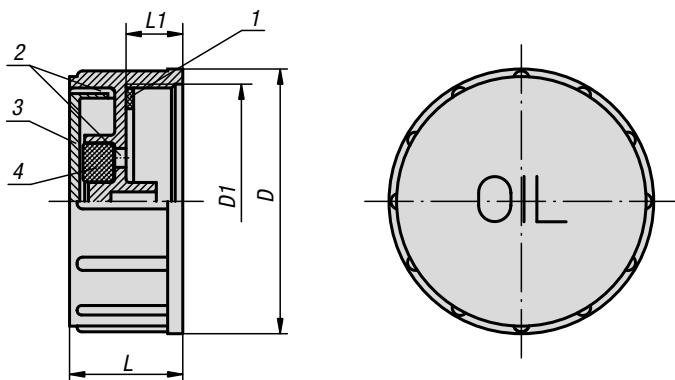

Material:

Housing and cap thermoplastic polyamide 66.
Air filter polyurethane (PU foam).
Flat seal NBR, Shore 70.

Version:

Black housing.
Red cap.
Filter mesh 40 µm.

Sample order:

K0456.67200

Temperature range:

Temperature resistant with oil up to 100°C.

On request:

Cap in yellow for diesel oil.

Drawing reference:

- 1) flat seal
- 2) vent
- 3) cap
- 4) air filter

KIPP Caps for filler necks

Order No.	D	D1	L	L1
K0456.67200	67,5	G2	30	15
K0456.676020	67,5	M60x2	30	15

Vent screws

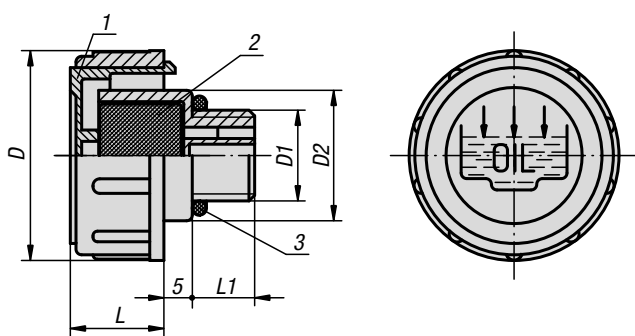

Material:

Housing, cap in thermoplastic polyamide 66.
Air filter (Form B only) in polyurethane (PU foam).
O-ring in rubber (NBR).

Version:

Black housing. Red cap. Filter mesh 60 µm.

Sample order:

K0457.147034

Note:

The removable cap allows easy cleaning of the air filter.

Form A: without air filter

Form B: with air filter

Temperature range:

Temperature resistant with oil up to 100°C.

Drawing reference:

- 1) cap
- 2) air filter Form B only
- 3) O-ring

KIPP Vent screws

Order No. Form A	Order No. Form B	D	D1	D2	L	L1
K0457.136038	K0457.236038	36	G3/8	23	17	11
K0457.141012	K0457.241012	41	G1/2	28	18	12
K0457.147034	K0457.247034	47	G3/4	33	17	12
K0457.152100	K0457.252100	52	G1	38	20	12
K0457.163114	K0457.263114	63	G1 1/4	49	23	13
K0457.163112	K0457.263112	63	G1 1/2	55	23	13,5
K0457.1361615	K0457.2361615	36	M16x1,5	23	17	11
K0457.1411815	K0457.2411815	41	M18x1,5	28	17,5	12
K0457.1412015	K0457.2412015	41	M20x1,5	28	17,5	12
K0457.1412215	K0457.2412215	41	M22x1,5	28	17,5	12