

## Hinges

plastic, with detent

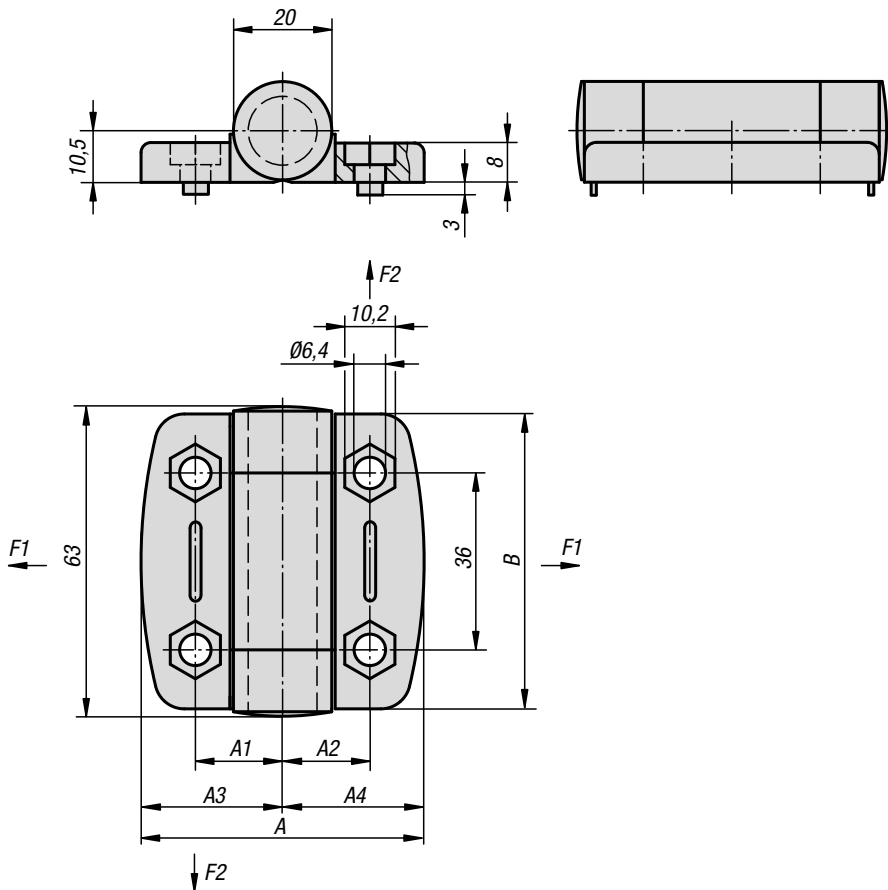

**Material:**

Hinge and caps fibreglass reinforced PA thermoplastic.  
Hinge pin stainless steel.

**Version:**

Hinge and caps black.  
Pin bright.

**Sample order:**

K0439.56181800

**Note:**

These hinges have a detent mechanism. This mechanism holds a door or lid open at three different angles or tightly closed. The hinges are available with or without guide tabs for aluminium profile slots.

The loading values given for the hinges are non-binding reference values without consideration of safety factors and exclude any liability. The values given are for information purposes only and do not constitute a legally binding assurance of properties.

The load values have been determined under laboratory conditions. Each user must determine individually whether the hinge is suitable for the respective application.

Different materials onto which the hinges are installed and the type of mounting, weather conditions and wear can influence the determined values.

### KIPP Hinges plastic, with detent

Order No.	A	A1	A2	A3	A4	B	Guide tabs for slot	F1 N	F2 N	Max. torque Nm
K0439.56181800	54	17,75	17,75	27	27	56	-	400	350	2
K0439.56181806	54	17,75	17,75	27	27	56	6	400	350	2
K0439.56181808	54	17,75	17,75	27	27	56	8	400	350	2
K0439.56232300	73,5	22,75	22,75	36,75	36,75	56	-	600	425	2
K0439.56232308	73,5	22,75	22,75	36,75	36,75	56	8	600	425	2
K0439.56232310	73,5	22,75	22,75	36,75	36,75	56	10	600	425	2