

Levelling feet plates

plastic

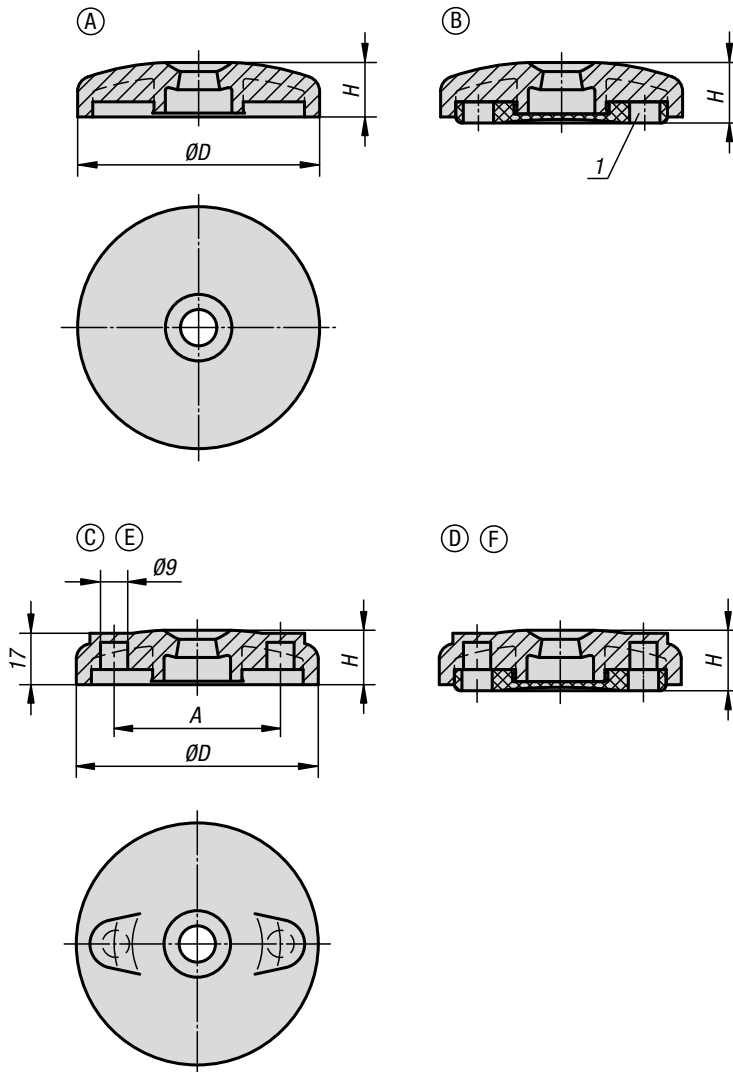

Material:

Plates, thermoplastic, fibreglass reinforced.
Anti-slip plate thermoplastic elastomer.

Version:

Black.

Sample order:

K0423.1060
K0423.1060 and K0427.120661 **assembled**

Note for ordering:

If the levelling foot plate and the threaded spindle are to be supplied assembled, please add the suffix “**assembled**” to the order number for the plate and spindle. (e.g. K0423.1060 and K0427.120661 **assembled**.)

Note:

Levelling feet consist of a plate and a threaded spindle. Any plate can be combined with any threaded spindle.
The anti-slip plate absorbs vibrations and prevents the levelling foot slipping.
For matching threaded spindles see K0427.

Drawing reference:

Form A without screw-on hole, without anti-slip plate
Form B without screw-on hole, with anti-slip plate
Form C with screw-on hole (closed), without anti-slip plate
Form D with screw-on hole (closed), with anti-slip plate
Form E with screw-on hole (open), without anti-slip plate
Form F with screw-on hole (open), with anti-slip plate

1) From plate $\varnothing 80$

KIPP Levelling feet plates plastic

Order No.	Form	D	A	H	Load rating max. kN
K0423.1060	A	60	-	18	12
K0423.1080	A	80	-	18	12
K0423.1100	A	100	-	18	12
K0423.2060	B	60	-	20	12
K0423.2080	B	80	-	20	12
K0423.2100	B	100	-	20	12
K0423.3080	C	80	55	18	12
K0423.3100	C	100	74	18	12
K0423.4080	D	80	55	20	12
K0423.4100	D	100	74	20	12
K0423.5080	E	80	55	18	12
K0423.5100	E	100	74	18	12
K0423.6080	F	80	55	20	12
K0423.6100	F	100	74	20	12