

## Indexing plungers

without collar

**Material:**

Steel version:  
Indexing pin hardened:  
Sleeve 1.0403 weldable.  
Indexing pin grade 5.8.

Stainless steel version:  
Indexing pin hardened:  
Sleeve 1.4301 weldable.  
Indexing pin 1.4034.

Indexing pin not hardened:  
Sleeve 1.4301 weldable.  
Indexing pin 1.4305.

Mushroom knob black grey thermoplastic.

**Version:**

Steel version:  
Indexing pin hardened, ground, black oxidised.

Stainless steel version:  
Indexing pin hardened, ground and bright.  
Indexing pin not hardened, ground and bright.

**Sample order:**

K0346.01206

**Note:**

Indexing plungers are used to prevent any change in locking position due to lateral forces. A new locking position can only be set after the pin has been manually disengaged.

Form M is recommended for applications where the indexing plungers should remain disengaged over an extended period and the pin prevented from springing back.

If the indexing plunger is welded on, the sleeve should be tack welded so that the spring is not thermally damaged due to high temperatures.

**On request:**

Special versions.

**Drawing reference:**

Form L: non-lockout type  
Form M: lockout type

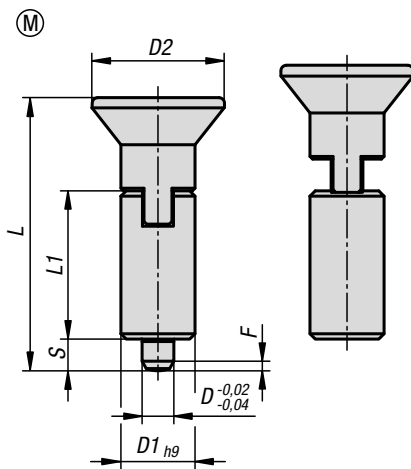
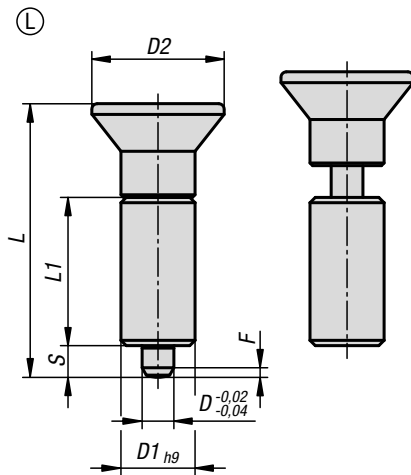

## Indexing plungers

without collar



## KIPP Indexing plungers without collar, steel, indexing pin hardened

Order No. Form L	Order No. Form M	D	D1	D2	L	L1	Travel S	Fx30°	Spring force initial pressure F1 approx. N	Spring force final pressure F2 approx. N
K0346.1004	K0346.2004	4	10	18	38,5	21	4	1	6	12
K0346.1105	K0346.2105	5	12	21	43,5	24	5	1,3	5	12
K0346.1206	K0346.2206	6	14	25	51,7	28	6	1,8	6	14
K0346.1308	K0346.2308	8	18	33	68	36	8	2,3	15	35
K0346.1410	K0346.2410	10	22	33	74	40	10	2,8	15	34

## KIPP Indexing plungers without collar, stainless steel, indexing pin hardened

Order No. Form L	Order No. Form M	D	D1	D2	L	L1	Travel S	Fx30°	Spring force initial pressure F1 approx. N	Spring force final pressure F2 approx. N
K0346.01004	K0346.02004	4	10	18	38,5	21	4	1	6	12
K0346.01105	K0346.02105	5	12	21	43,5	24	5	1,3	5	12
K0346.01206	K0346.02206	6	14	25	51,7	28	6	1,8	6	14
K0346.01308	K0346.02308	8	18	33	68	36	8	2,3	15	35
K0346.01410	K0346.02410	10	22	33	74	40	10	2,8	15	34

## KIPP Indexing plungers without collar, stainless steel, indexing pin not hardened

Order No. Form L	Order No. Form M	D	D1	D2	L	L1	Travel S	Fx30°	Spring force initial pressure F1 approx. N	Spring force final pressure F2 approx. N
K0346.11004	K0346.12004	4	10	18	38,5	21	4	1	6	12
K0346.11105	K0346.12105	5	12	21	43,5	24	5	1,3	5	12
K0346.11206	K0346.12206	6	14	25	51,7	28	6	1,8	6	14
K0346.11308	K0346.12308	8	18	33	68	36	8	2,3	15	35
K0346.11410	K0346.12410	10	22	33	74	40	10	2,8	15	34