

Spring plungers

with hex socket and ball, stainless steel, with thread lock



Material:
Sleeve 1.4305.
Ball 1.4034.
Spring 1.4310.

Thread lock nylon.

Version:
Bright. Ball hardened.

Sample order:
K0326.08

Drawing reference:
L2 = approx. 2x thread pitch

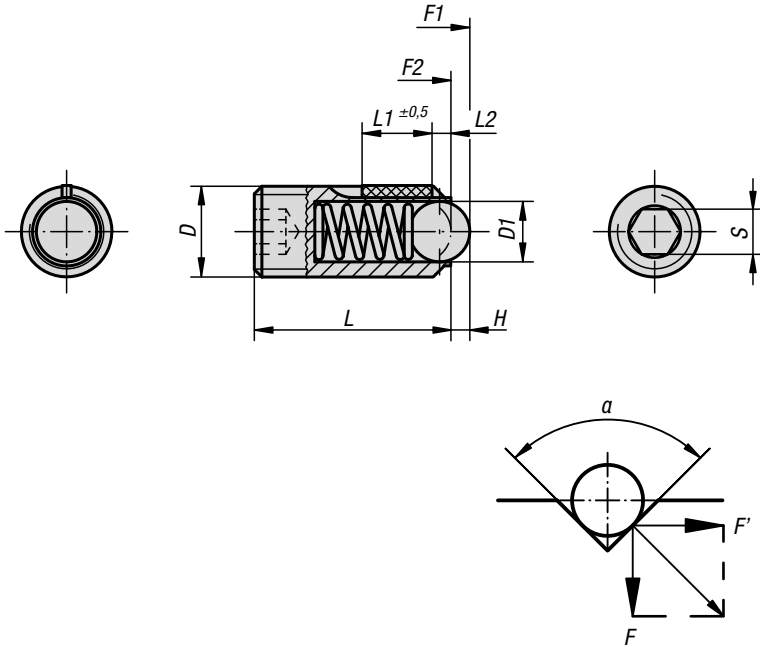

$$a = 60^\circ, F' = 1,732 \times F$$

$$a = 90^\circ, F' = F$$

$$a = 120^\circ, F' = 0,577 \times F$$

KIPP Spring plungers with hex socket and ball, standard spring force, with thread lock

Order No.	D	D1	H	L	L1	S	Spring force initial pressure F1 approx. N	Spring force final pressure F2 approx. N	Tightening torque approx. Nm	Loosening torque approx. Nm
K0326.03	M3	1,5	0,4	9	4	1,5	1,5	3	0,1	0,07
K0326.04	M4	2,5	0,8	10	5	2	4	10	0,18	0,12
K0326.05	M5	3	0,9	14	6	2,5	6	11	0,12	0,08
K0326.06	M6	3,5	1	15	7	3	9	13	0,44	0,21
K0326.08	M8	5	1,5	18	8	4	15	30	1,1	0,38
K0326.10	M10	6	2	23	9	5	20	35	1,3	0,6
K0326.12	M12	8	2,5	26	10	6	30	55	2	1,3
K0326.16	M16	10	3,5	33	14	8	65	125	3,9	3

KIPP Spring plungers with hex socket and ball, heavy spring force, with thread lock

Order No.	D	D1	H	L	L1	S	Spring force initial pressure F1 approx. N	Spring force final pressure F2 approx. N	Tightening torque approx. Nm	Loosening torque approx. Nm
K0326.203	M3	1,5	0,4	9	4	1,5	5	7	0,1	0,07
K0326.204	M4	2,5	0,8	10	5	2	12	22	0,18	0,12
K0326.205	M5	3	0,9	14	6	2,5	19	30	0,12	0,08
K0326.206	M6	3,5	1	15	7	3	28	40	0,44	0,21
K0326.208	M8	5	1,5	18	8	4	47	73	1,1	0,38
K0326.210	M10	6	2	23	9	5	66	100	1,3	0,6
K0326.212	M12	8	2,5	26	10	6	66	120	2	1,3
K0326.216	M16	10	3,5	33	14	8	90	180	3,9	3