

## Spring plungers

with hex socket and ball, steel, with thread lock

**KIPPl**ock

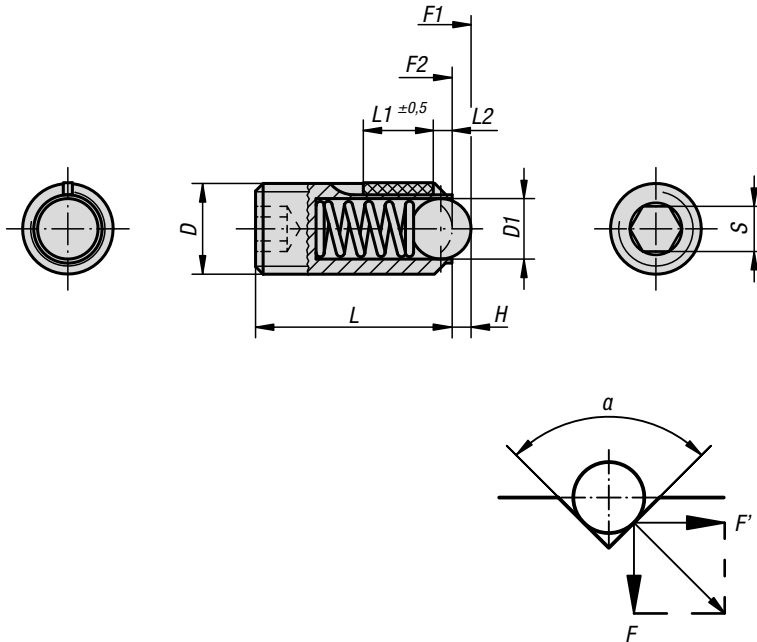

$$a = 60^\circ, F' = 1,732 \times F$$

$$a = 90^\circ, F' = F$$

$$a = 120^\circ, F' = 0,577 \times F$$

**Material:**

Sleeve steel grade 5.8.  
Ball steel.  
Spring grade D spring steel wire.

Thread lock nylon.

**Version:**

Black oxidised. Ball hardened.

**Sample order:**

K0325.08

**Drawing reference:**

L2 = approx. 2x thread pitch

### KIPPl Spring plungers with hex socket and ball, standard spring force, with thread lock

Order No.	D	D1	H	L	L1	S	Spring force initial pressure F1 approx. N	Spring force final pressure F2 approx. N	Tightening torque approx. Nm	Loosening torque approx. Nm
K0325.03	M3	1,5	0,4	9	4	1,5	1,5	3	0,1	0,07
K0325.04	M4	2,5	0,8	10	5	2	4	10	0,18	0,12
K0325.05	M5	3	0,9	14	6	2,5	6	11	0,12	0,08
K0325.06	M6	3,5	1	15	7	3	9	13	0,44	0,21
K0325.08	M8	5	1,5	18	8	4	15	30	1,1	0,38
K0325.10	M10	6	2	23	9	5	20	40	1,3	0,6
K0325.12	M12	8	2,5	26	10	6	30	55	2	1,3
K0325.16	M16	10	3,5	33	14	8	65	125	3,9	3

### KIPPl Spring plungers with hex socket and ball, heavy spring force, with thread lock

Order No.	D	D1	H	L	L1	S	Spring force initial pressure F1 approx. N	Spring force final pressure F2 approx. N	Tightening torque approx. Nm	Loosening torque approx. Nm
K0325.203	M3	1,5	0,4	9	4	1,5	5	7	0,1	0,07
K0325.204	M4	2,5	0,8	10	5	2	12	22	0,18	0,12
K0325.205	M5	3	0,9	14	6	2,5	19	30	0,12	0,08
K0325.206	M6	3,5	1	15	7	3	28	40	0,44	0,21
K0325.208	M8	5	1,5	18	8	4	47	73	1,1	0,38
K0325.210	M10	6	2	23	9	5	66	100	1,3	0,6
K0325.212	M12	8	2,5	26	10	6	66	120	2	1,3
K0325.216	M16	10	3,5	33	14	8	90	180	3,9	3