

Spring plungers

with hexagon socket and POM thrust pin, steel

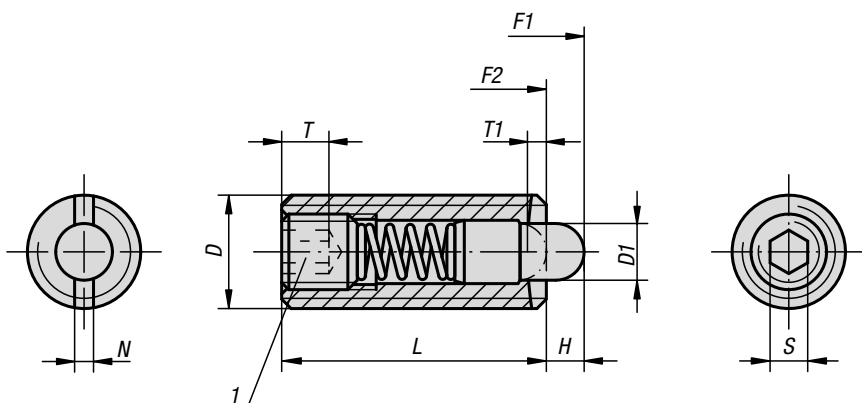

Material:
Sleeve steel grade 5.8.
Thrust pin POM.
Spring grade D steel wire.

Version:
Black oxidised.

Sample order:
K0318.16

Drawing reference:
1) grub screw glued in

application example

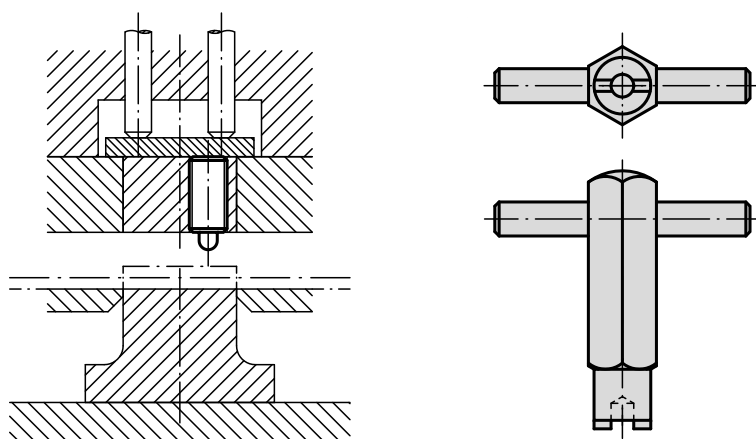

KIPP Spring plungers with hexagon socket and thrust pin, standard spring force

Order No.	D	D1	H	L	T	T1	N	S	Spring force initial pressure F1 approx. N	Spring force final pressure F2 approx. N	Order No. Assembly key
K0318.03	M3	1	1,5	10	1,5	1	0,4	0,7	0,5	3	K0317.903
K0318.04	M4	1,5	1,5	15	2	0,6	0,6	1,3	5	16	K0317.904
K0318.05	M5	2,4	2,3	18	2	0,8	0,8	1,5	6	20	K0317.905
K0318.06	M6	2,7	2,5	20	2,5	1	1	2	7	20	K0317.906
K0318.08	M8	3,5	3	22	3	1,4	1,2	2,5	9	35	K0317.908
K0318.10	M10	4	3	22	3,5	1,4	1,6	3	9	35	K0317.910
K0318.12	M12	6	4	28	5	2	2	4	12	55	K0317.912
K0318.16	M16	7,5	5	32	6	2,5	2,5	5	45	100	K0317.916

KIPP Spring plungers with hexagon socket and thrust pin, light spring force

Order No.	D	D1	H	L	T	T1	N	S	Spring force initial pressure F1 approx. N	Spring force final pressure F2 approx. N	Order No. Assembly key
K0318.104	M4	1,5	1,5	15	2	0,6	0,6	1,3	2	7	K0317.904
K0318.105	M5	2,4	2,3	18	2	0,8	0,8	1,5	3	10	K0317.905
K0318.106	M6	2,7	2,5	20	2,5	1	1	2	3	9	K0317.906
K0318.108	M8	3,5	3	22	3	1,4	1,2	2,5	4	16	K0317.908
K0318.110	M10	4	3	22	3,5	1,4	1,6	3	4	16	K0317.910
K0318.112	M12	6	4	28	5	2	2	4	5	27	K0317.912
K0318.116	M16	7,5	5	32	6	2,5	2,5	5	20	45	K0317.916