

Spring plungers

with hexagon socket and thrust pin, steel

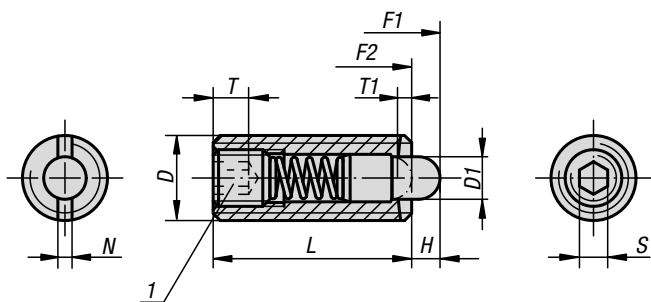

Material:

Sleeve steel grade 5.8.
Thrust pin steel.
Spring steel wire grade D.

Version:

Black oxidised.
Thrust pin hardened.

Sample order:

K0317.16

Drawing reference:

1) grub screw glued in

application example

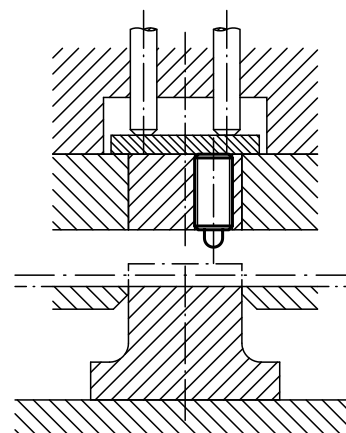

Spring plungers

with hexagon socket and thrust pin, steel

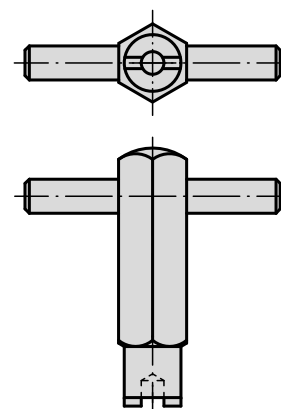

KIPP Spring plungers with hexagon socket and thrust pin, standard spring force

Order No.	D	D1	H	L	T	T1	N	S	Spring force initial pressure F1 approx. N	Spring force final pressure F2 approx. N	Order No. Assembly key
K0317.03	M3	1	1,5	10	1,5	1	0,4	0,7	0,5	3	K0317.903
K0317.04	M4	1,5	1,5	15	2	0,6	0,6	1,3	5	16	K0317.904
K0317.05	M5	2,4	2,3	18	2	0,8	0,8	1,5	6	20	K0317.905
K0317.06	M6	2,7	2,5	20	2,5	1	1	2	7	20	K0317.906
K0317.08	M8	3,5	3	22	3	1,4	1,2	2,5	9	35	K0317.908
K0317.10	M10	4	3	22	3,5	1,4	1,6	3	9	35	K0317.910
K0317.12	M12	6	4	28	5	2	2	4	12	55	K0317.912
K0317.16	M16	7,5	5	32	6	2,5	2,5	5	45	100	K0317.916
K0317.20	M20	10	7	40	8	3	2,5	6	60	120	-
K0317.24	M24	12	10	52	10	3	2,5	8	80	160	-

KIPP Spring plungers with hexagon socket and thrust pin, light spring force

Order No.	D	D1	H	L	T	T1	N	S	Spring force initial pressure F1 approx. N	Spring force final pressure F2 approx. N	Order No. Assembly key
K0317.104	M4	1,5	1,5	15	2	0,6	0,6	1,3	2	7	K0317.904
K0317.105	M5	2,4	2,3	18	2	0,8	0,8	1,5	3	10	K0317.905
K0317.106	M6	2,7	2,5	20	2,5	1	1	2	3	9	K0317.906
K0317.108	M8	3,5	3	22	3	1,4	1,2	2,5	4	16	K0317.908
K0317.110	M10	4	3	22	3,5	1,4	1,6	3	4	16	K0317.910
K0317.112	M12	6	4	28	5	2	2	4	5	27	K0317.912
K0317.116	M16	7,5	5	32	6	2,5	2,5	5	20	45	K0317.916

KIPP Spring plungers with hexagon socket and thrust pin, reinforced spring force

Order No.	D	D1	H	L	T	T1	N	S	Spring force initial pressure F1 approx. N	Spring force final pressure F2 approx. N	Order No. Assembly key
K0317.205	M5	2,4	2,3	18	2	0,8	0,8	1,5	11	29	K0317.905
K0317.206	M6	2,7	2,5	20	2,5	1	1	2	14	37	K0317.906
K0317.208	M8	3,5	3	22	3	1,4	1,2	2,5	22	65	K0317.908
K0317.210	M10	4	3	22	3,5	1,4	1,6	3	19	70	K0317.910
K0317.212	M12	6	4	28	5	2	2	4	25	85	K0317.912
K0317.216	M16	7,5	5	32	6	2,5	2,5	5	60	150	K0317.916
K0317.220	M20	10	7	40	8	3	2,5	6	75	190	-
K0317.224	M24	12	10	52	10	3	2,5	8	95	240	-