

## Spring plungers

with slot and POM ball, plastic

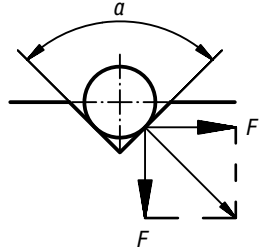
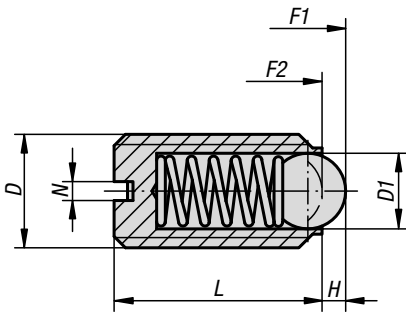

$$a = 60^\circ, F' = 1,732 \times F$$

$$a = 90^\circ, F' = F$$

$$a = 120^\circ, F' = 0,577 \times F$$



**Material:**  
Sleeve plastic.  
Ball POM.  
Spring 1.4310 wire.

**Version:**  
Ball, white.

**Sample order:**  
K0311.10

**Note:**  
Spring plungers are used for indexing and positioning.  
They can also be used as ejectors.

### KIPP Spring plungers with slot and POM ball, plastic

Order No.	D	D1	H	L	N	Spring force initial pressure F1 approx. N	Spring force final pressure F2 approx. N
K0311.06	M6	3,5	1	14	1	9	13
K0311.08	M8	5	1,5	16	1,2	15	30
K0311.10	M10	6	2	19	1,6	20	40

# K0312

## Spring plungers

with slot and stainless steel ball, plastic

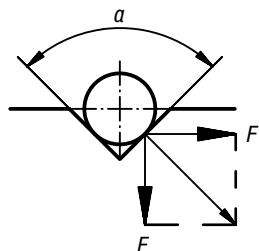
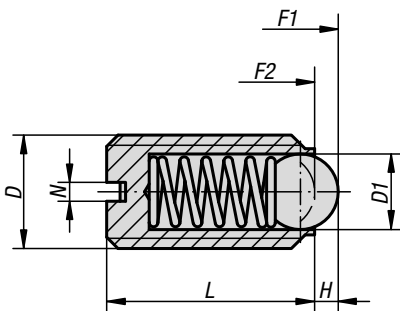

$$a = 60^\circ, F' = 1,732 \times F$$

$$a = 90^\circ, F' = F$$

$$a = 120^\circ, F' = 0,577 \times F$$



**Material:**  
Sleeve plastic.  
Ball 1.4034 stainless steel.  
Spring 1.4310.

**Version:**  
Ball, hardened.

**Sample order:**  
K0312.10

**Note:**  
Spring plungers are used for indexing and positioning.  
They can also be used as ejectors.

### KIPP Spring plungers with slot and stainless steel ball, plastic

Order No.	D	D1	H	L	N	Spring force initial pressure F1 approx. N	Spring force final pressure F2 approx. N
K0312.06	M6	3,5	1	14	1	9	13
K0312.08	M8	5	1,5	16	1,2	15	30
K0312.10	M10	6	2	19	1,6	20	40