

Rest pads

with positioning pin

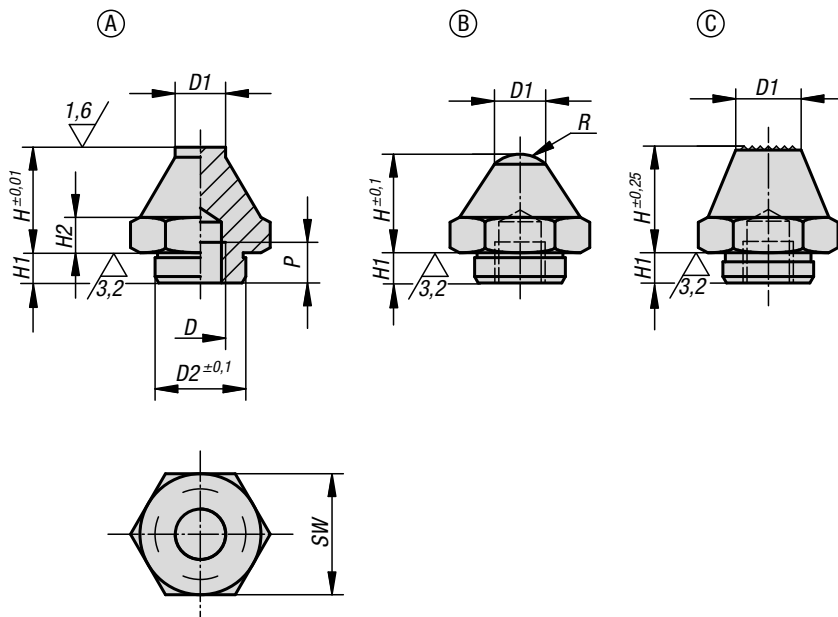

Material:

Body high carbon steel.

Version:

Body tempered and black oxidised.
Contact faces case-hardened.

Sample order:

K0295.106012

Note:

Rest pads are for supporting machined and unmachined parts. They can also be used as stops and thrust pads in fixtures and toolmaking. Studs or grub screws can be screwed and glued into the tapped hole D to make a support with external thread.

Drawing reference:

Form A: flat face

Form B: ball end

Form C: diamond grip

KIPP Rest pads with positioning pin

Order No.	Form	D	D1	D2	H	H1	H2	P	R	SW
K0295.106012	A	M6	7	11,9	12,5	4	4	6	-	17
K0295.106025	A	M6	7	11,9	25	4	4	6	-	17
K0295.110020	A	M10	10	17,8	20	5	7	10	-	24
K0295.110040	A	M10	10	17,8	40	6	7	10	-	24
K0295.116030	A	M16	20	25,8	30	10	13	16	-	41
K0295.116060	A	M16	20	25,8	60	10	13	16	-	41
K0295.206012	B	M6	7	11,9	12,5	4	4	6	6	17
K0295.206025	B	M6	7	11,9	25	4	4	6	6	17
K0295.210020	B	M10	10	17,8	20	5	7	10	7,5	24
K0295.210040	B	M10	10	17,8	40	6	7	10	7,5	24
K0295.216030	B	M16	20	25,8	30	10	13	16	26	41
K0295.216060	B	M16	20	25,8	60	10	13	16	26	41
K0295.310020	C	M10	10	17,8	20	5	7	10	-	24
K0295.310040	C	M10	10	17,8	40	6	7	10	-	24
K0295.316030	C	M16	20	25,8	30	10	13	16	-	41
K0295.316060	C	M16	20	25,8	60	10	13	16	-	41