



Material:
Body high carbon steel.

Version:
Body tempered and black oxidised.

Sample order:
K0294.106012

Note:
Rest pads are for supporting machined and non-machined parts. They can also be used as stops and thrust pads in fixtures and toolmaking. Studs or grub screws can be screwed and glued into the tapped hole D to make a rest pad with external thread.

Drawing reference:
Form A: flat face
Form B: ball end
Form C: diamond grip

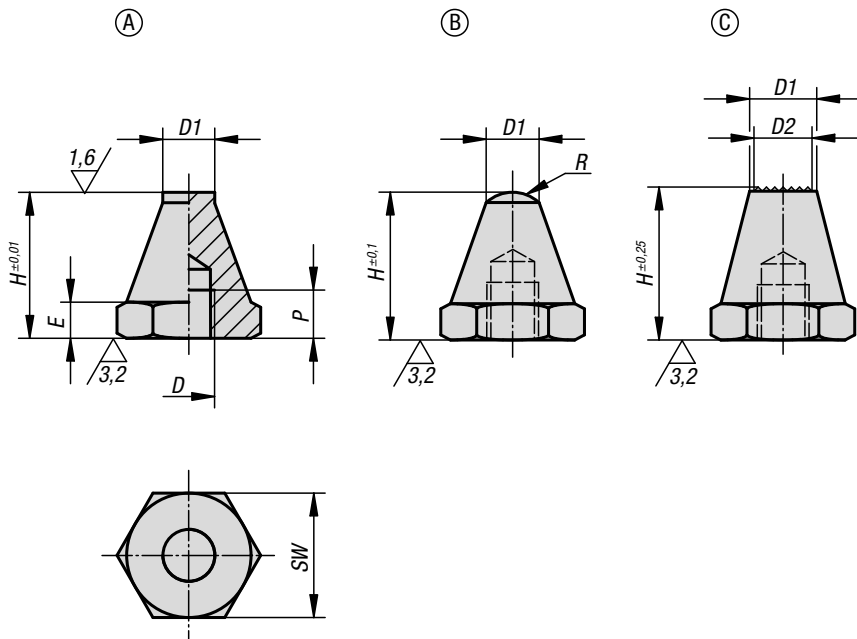

KIPP Rest pads

Order No. Form A	Order No. Form B	Order No. Form C	D	D1	D2	E	H	P	R	SW
K0294.106012	K0294.206012	K0294.306012	M6	6	-/-/5	3	12,5	4	-/5/-	11
K0294.106025	K0294.206025	K0294.306025	M6	6	-/-/5	3	25	7	-/5/-	11
K0294.108015	K0294.208015	K0294.308015	M8	8	-/-/6	4	15	6	-/8,5/-	13
K0294.108030	K0294.208030	K0294.308030	M8	8	-/-/6	4	30	9	-/8,5/-	13
K0294.110020	K0294.210020	K0294.310020	M10	10	-/-/8	5	20	9	-/9/-	17
K0294.110040	K0294.210040	K0294.310040	M10	10	-/-/8	5	40	13	-/9/-	17
K0294.112025	K0294.212025	K0294.312025	M12	12	-/-/9,5	6	25	11	-/12,75/-	19
K0294.112050	K0294.212050	K0294.312050	M12	12	-/-/9,5	6	50	16	-/12,75/-	19
K0294.116030	K0294.216030	K0294.316030	M16	16	-/-/13	8	30	12	-/17/-	24
K0294.116060	K0294.216060	K0294.316060	M16	16	-/-/13	8	60	20	-/17/-	24