

Locating pins and rest pads

DIN 6321 (Issue 1973)



Material:
Tool steel.

Version:
Hardened and ground.

Sample order:
K0293.212

Note:

Rest pads Form A are supports for workpieces and fixtures.
Locating pins Form B are for positioning workpieces and fixture components in reamed holes.
The flattened Form C can be used to bridge tolerances in hole spacing or to secure the part to be positioned in one direction only.
Form A and B can also be used as hardened stops and as fixture feet.
For similar pins see K0352, K0353, K0354 and K0355.

Drawing reference:

Form A: Rest pad
Form B: Cylindrical locating pin
Form C: Flattened locating pin

For other dimensions see Form A.

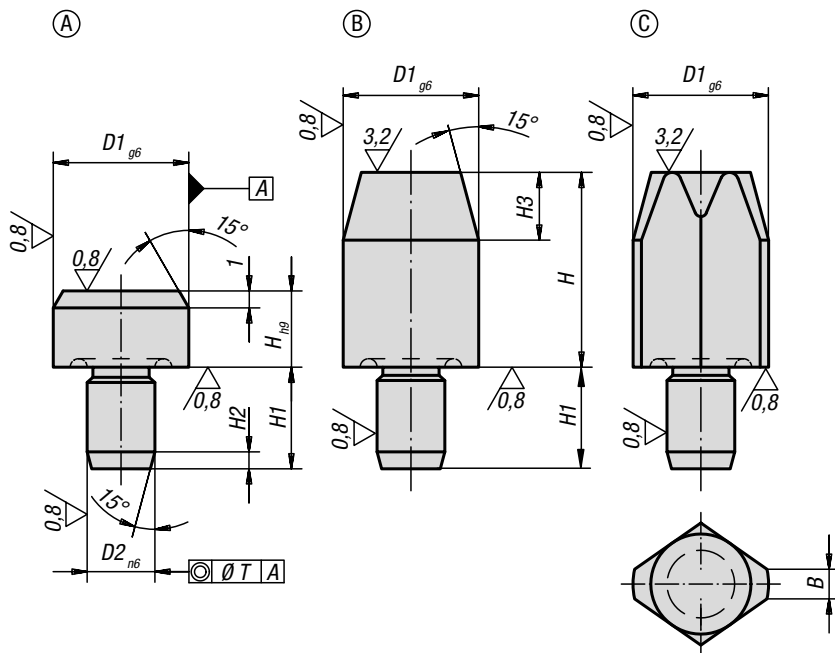

KIPP Rest pads, Form A

Order No. without centre bore	D1	D2	H	H1	H2	T
K0293.106	6	4	5	6	1,2	0,02
K0293.110	10	6	6	9	1,6	0,02
K0293.116	16	8	8	12	2	0,04
K0293.125	25	12	10	18	2,5	0,04

KIPP Locating pin cylindrical, Form B

Order No. short	Order No. long	D1	D2	H	H1	H2	H3	T
K0293.206	K0293.306	6	4	7/12	6	1,2	4	0,02
K0293.208	K0293.308	8	6	10/16	9	1,6	6	0,02
K0293.210	K0293.310	10	6	10/18	9	1,6	6	0,02
K0293.212	K0293.312	12	6	10/18	9	1,6	6	0,02
K0293.216	K0293.316	16	8	13/22	12	2	8	0,04
K0293.220	K0293.320	20	12	15/25	18	2	9	0,04
K0293.225	K0293.325	25	12	15/25	18	2,5	9	0,04

KIPP Locating pin rhombic, Form C

Order No. short	Order No. long	B	D1	D2	H	H1	H2	H3	T
K0293.406	K0293.506	1	6	4	7/12	6	1,2	4	0,02
K0293.408	K0293.508	1,6	8	6	10/16	9	1,6	6	0,02
K0293.410	K0293.510	2,5	10	6	10/18	9	1,6	6	0,02
K0293.412	K0293.512	2,5	12	6	10/18	9	1,6	6	0,02
K0293.416	K0293.516	3,5	16	8	13/22	12	2	8	0,04
K0293.420	K0293.520	5	20	12	15/25	18	2	9	0,04
K0293.425	K0293.525	5	25	12	15/25	18	2,5	9	0,04

