

Self-aligning pads

with o-ring

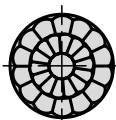
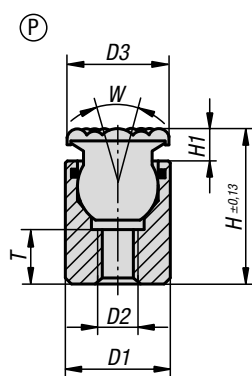
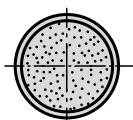
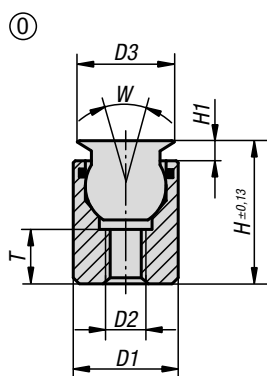
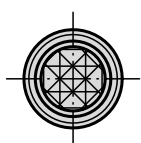
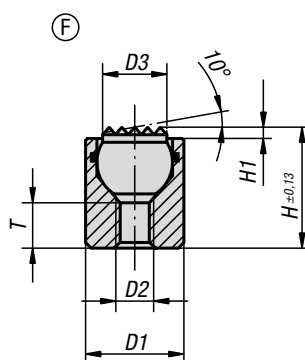
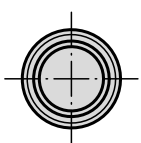
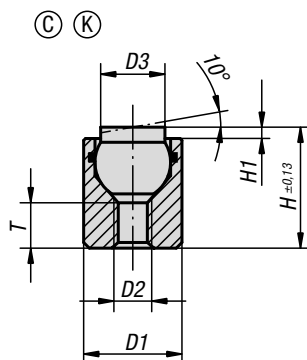

Material:

Body carbon steel.

Ball:

Form C, F tool steel.

Form K POM.

Form O stainless steel diamond impregnated.

Form P stainless steel with polyurethane face.

Version:

Body tempered, black oxidised.

Ball:

Form C, F hardened, black oxidised.

Form K POM ball, white.

Form O surface comparable to 100 grade abrasive grit.

Form P polyurethane, hardness 60 Shore.

Sample order:

K0284.704X012

Note:

Self-aligning pads are used to support and clamp unmachined and machined workpieces.

They also serve as stops, supports and thrust pads in fixtures and toolmaking.

Ball secured against rotation.

Form O: The abrasive diamond surface is fused firmly to the ball. It is ideally suited to supporting smooth or slippery applications with a minimum of clamping pressure. This allows the diamond particles to get a firm grip on a very small area with minimum damage to the surface. The diamond surface offers excellent wear resistance.

Form P: The polyurethane surface is permanently vulcanised on the ball. It is abrasion-resistant and does not discolour. Offers optimum protection against damage to delicate surfaces. The pearl-like surface gives a firm grip and allows air to escape so as to prevent any suction effect between the contact surface and the self-aligning pads.

Advantages:

The built-in O-ring holds the ball in place and keeps dirt and foreign particles out ensuring smooth and even movement.

Self-aligning pads

with o-ring



KIPP Form C, flattened steel ball, smooth

Order No.	Form	D1	D2	D3	H	H1	T	Ball-Ø	Load rating max. kN (static load only)
K0284.104X012	C	10	M4	6	12	1,5	4,5	7	12
K0284.104X025	C	10	M4	6	25	1,5	12	7	12
K0284.105X016	C	13	M5	8,5	16	1,5	5	10	20
K0284.105X025	C	13	M5	8,5	25	1,5	12	10	20

KIPP Form F, flattened steel ball, diamond grip

Order No.	Form	D1	D2	D3	H	H1	T	Ball-Ø	Load rating max. kN (static load only)
K0284.304X012	F	10	M4	6	12	1,5	4,5	7	12
K0284.304X025	F	10	M4	6	25	1,5	12	7	12
K0284.305X016	F	13	M5	8,5	16	1,5	5	10	20
K0284.305X025	F	13	M5	8,5	25	1,5	12	10	20

KIPP Form K, flattened POM ball, smooth

Order No.	Form	D1	D2	D3	H	H1	T	Ball-Ø	Load rating max. kN (static load only)
K0284.704X012	K	10	M4	6	12	1,5	4,5	7	2
K0284.704X025	K	10	M4	6	25	1,5	12	7	2
K0284.705X016	K	13	M5	8,5	16	1,5	5	10	4
K0284.705X025	K	13	M5	8,5	25	1,5	12	10	4

KIPP Form O, stainless-steel ball, diamond impregnated

Order No.	Form	D1	D2	D3	H	H1	T	W	Ball-Ø	Load rating max. kN (static load only)
K0284.504X012	O	10	M4	8	12,5	2	3,5	28	7	11,5
K0284.504X025	O	10	M4	8	25,5	2	9	28	7	11,5
K0284.505X017	O	13	M5	11	17,5	3	6,5	28	10	19,8
K0284.505X026	O	13	M5	11	26,5	3	9	28	10	19,8
K0284.506X021	O	17	M6	14	21	3	7,5	28	13	27,4
K0284.508X024	O	19	M8	19	24	4	8,5	24	15	38,6
K0284.510X028	O	24	M10	21	28	4	9	24	20	58,3

KIPP Form P, stainless-steel ball with polyurethane face

Order No.	Form	D1	D2	D3	H	H1	W	T	Ball-Ø
K0284.604X014	P	10	M4	10	14,5	4	28	3,5	7
K0284.604X027	P	10	M4	10	27,5	4	28	9	7
K0284.605X019	P	13	M5	13	19,5	5	28	6,5	10
K0284.605X028	P	13	M5	13	28,5	5	28	9	10
K0284.606X023	P	17	M6	16	23	5	28	7,5	13
K0284.608X026	P	19	M8	21	26	6	24	8,5	15
K0284.610X030	P	24	M10	23	30	6	24	9	20