

Self-aligning pads

swivel angle 14° and 20°

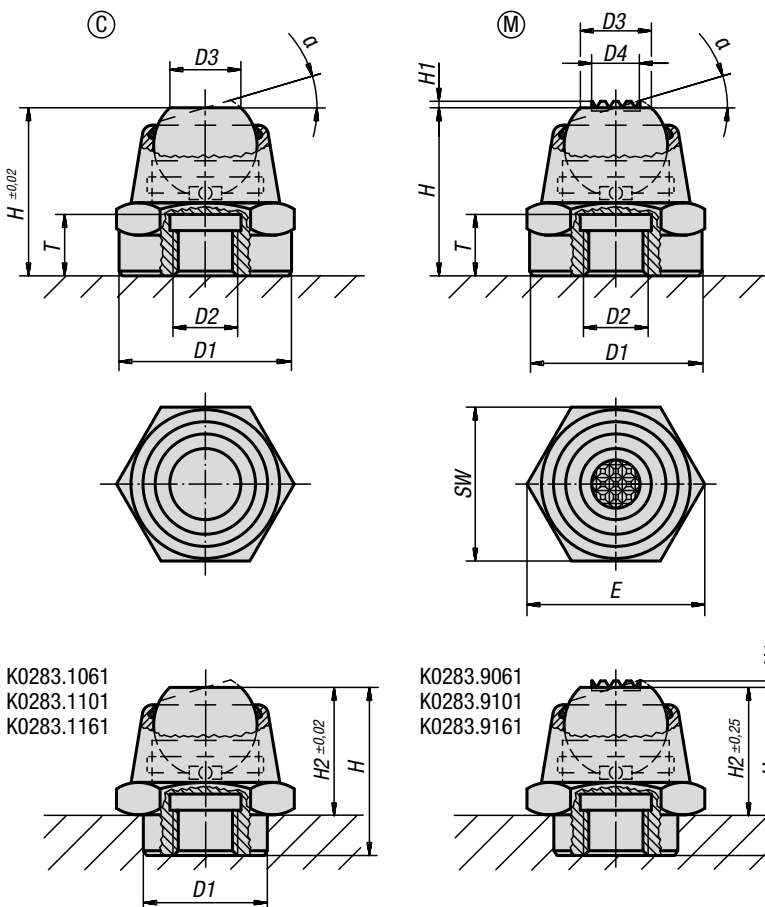

Material:

Body steel.
Ball rust and acid resistant steel.
Form M with carbide insert.

Version:

Body black oxidised.
Ball bright.

Sample order:

K0283.108

Note:

Self-aligning pads are used to support and clamp unmachined and machined workpieces. They also serve as stops, supports and thrust pads in fixture and toolmaking.

Grub screws or threaded studs can be screwed and glued into thread D2 making a self-aligning pad with external thread.

Ball secured against rotation.

Advantages:

- Self-aligning pads can be swiveled.
- High load forces can be absorbed.
- The built-in o-ring keeps dirt and foreign particles out, which in turn guarantees reliable operation.

KIPP Form C, flattened ball, flat face

Order No.	Form	α	D1	D2	D3	H	H2	T	E	SW	Ball-Ø	Load rating max. kN (static load only)
K0283.1061	C	14°	12	M6	7	17,5	12,5	6	19,6	17	10	14
K0283.106	C	14°	16	M6	7	17,5	-	6	19,6	17	10	14
K0283.108	C	20°	22	M8	11	26	-	9	27,7	24	16	34
K0283.1101	C	20°	18	M10	11	26	20	9	27,7	24	16	34
K0283.110	C	20°	22	M10	11	26	-	9	27,7	24	16	34
K0283.112	C	20°	22	M12	11	26	-	9	27,7	24	16	34
K0283.1161	C	20°	26	M16	18	40	30	15	41,6	36	25	90
K0283.116	C	20°	34	M16	18	40	-	15	41,6	36	25	90
K0283.120	C	20°	34	M20	18	40	-	15	41,6	36	25	90

KIPP Form M, flattened ball, carbide steel diamond grip

Order No.	Form	α	D1	D2	D3	D4	H	H1	H2	E	T	Ball-Ø	SW	Load rating max. kN (static load only)
K0283.9061	M	14°	12	M6	7	5	17,5	0,6	12,5	19,6	6	10	17	14
K0283.906	M	14°	16	M6	7	5	17,5	0,6	-	19,6	6	10	17	14
K0283.908	M	20°	22	M8	11	7,5	26	0,8	-	27,7	9	16	24	34
K0283.9101	M	20°	18	M10	11	7,5	26	0,8	20	27,7	9	16	24	34
K0283.910	M	20°	22	M10	11	7,5	26	0,8	-	27,7	9	16	24	34
K0283.912	M	20°	22	M12	11	7,5	26	0,8	-	27,7	9	16	24	34
K0283.9161	M	20°	26	M16	18	13	40	0,9	30	41,6	15	25	36	90
K0283.916	M	20°	34	M16	18	13	40	0,9	-	41,6	15	25	36	90
K0283.920	M	20°	34	M20	18	13	40	0,9	-	41,6	15	25	36	90