

## Toggle presses for manual operation

### Item description/product images

---



### Description

**Material:**

Press stand cast steel.

For push-pull clamp see K0088

**Version:**

Press stand painted black.

For push-pull clamp see K0088

**Note:**

Push-Pull toggle clamps with reversible lever can be re-ordered as a complete assembly set. For technical data and clamping forces, see K0088.

Due to the casting process, the holes and threads may deviate from the centre axis of the press stand.

**Accessory:**

K0088

K0099

K0101

K0102

K0103

K0106

**Drawing reference:**

1) handle can be mounted right or left

# Toggle presses for manual operation

## Drawings

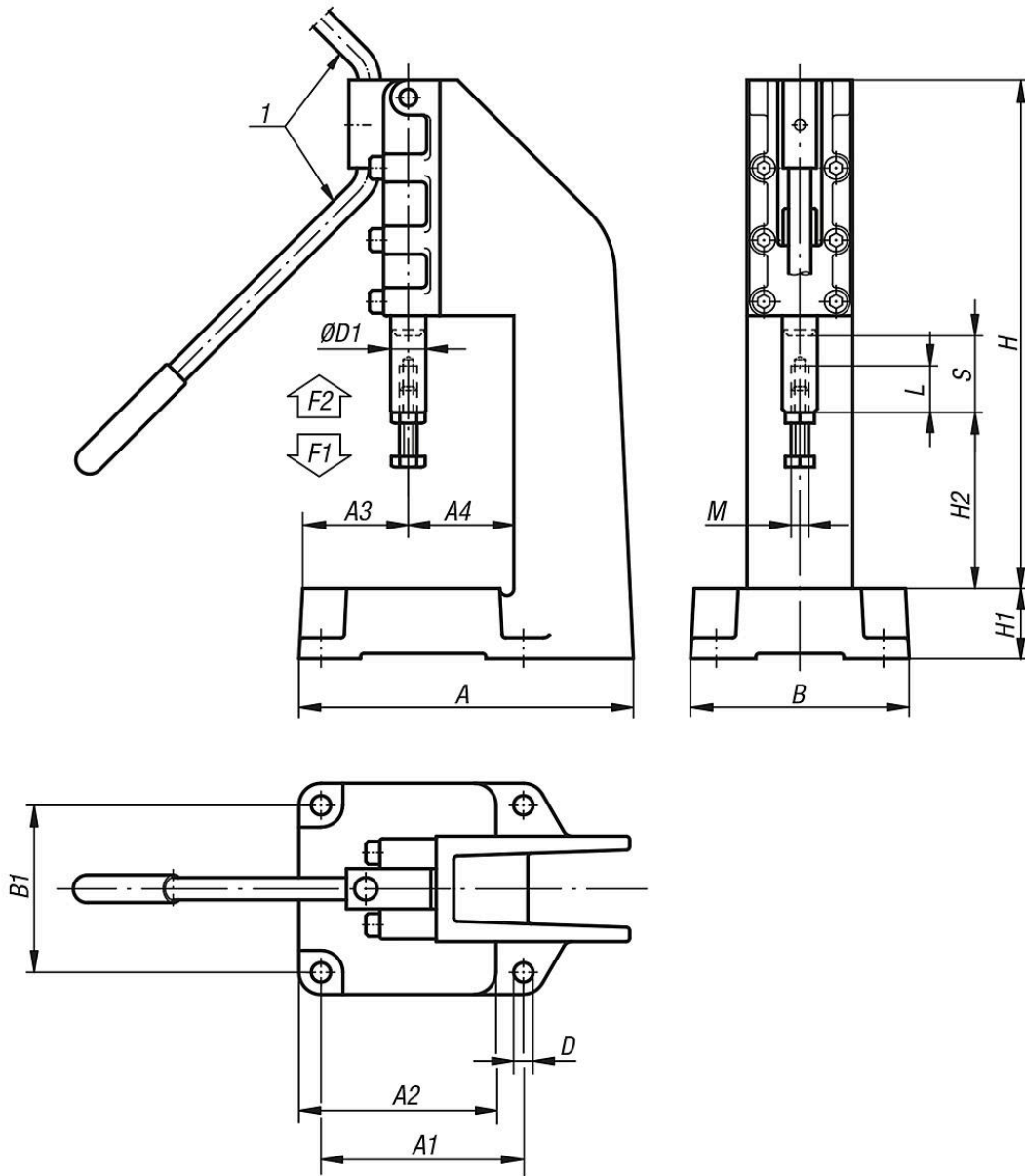

## Overview of items

### Toggle presses for manual operation

Order No.	A	A1	A2	A3	A4	B	B1	D	D1	H	H1	H2	L	M	Travel S	Hand force FH N	Retaining force F2 N	Opening angle of handle
K0095.0600	150	95	94	50	50	100	80	9	14	202	30	75	30	M8	32	140	6000	185°
K0095.1200	192	115	112	60	60	120	95	11	20	290	40	100	40	M10	50	150	12000	185°
K0095.2500	238	145	142	75	75	150	125	11	25	418	50	120	60	M12	75	170	25000	185°

Order No.	Thrust rod extended / Clamping force F1 N
K0095.0600	5mm/1100N, 10mm/700N, 15mm/750N, 20mm/800N, 25mm/850N, 30mm/1460N, 31mm/1900N, 32mm/5800N
K0095.1200	5mm/1670N, 10mm/900N, 15mm/730N, 20mm/700N, 25mm/720N, 30mm/850N, 35mm/1000N, 40mm/1100N, 45mm/1500N, 48mm/2200N, 49mm/2900N, 50mm/9300N
K0095.2500	10mm/1000N, 20mm/720N, 30mm/600N, 40mm/700N, 50mm/880N, 60mm/1180N, 70mm/1900N, 72mm/2300N, 74mm/3530N, 75mm/11000N

