

Wedge clamps double wedge

jaw faces serrated



Material:

Body and jaw segments tool steel.

Version:

Body hardened.

Jaw segments hardened (49-51 HRC) and black oxidised.

Wedge faces ground.

Sample order:

K0042.1214

Note:

The compact design makes these double wedge clamps ideal for horizontal and vertical series clamping. The hardened and ground wedge faces can exert high clamping forces.

These wedge clamps can be mounted in grid holes or T-slots. Tightening the DIN 912 socket screw pulls the wedges together and the jaws out pressing the workpieces against the fixtures fixed stops.

The double wedges create a positive down force.

Spread width:

K0042.12 = ±1.0 mm

K0042.16 = ±1.5 mm

Drawing reference:

D) DIN 912 cap screw

- 1) Wedge clamps
- 2) Workpiece
- 3) Fixed stop

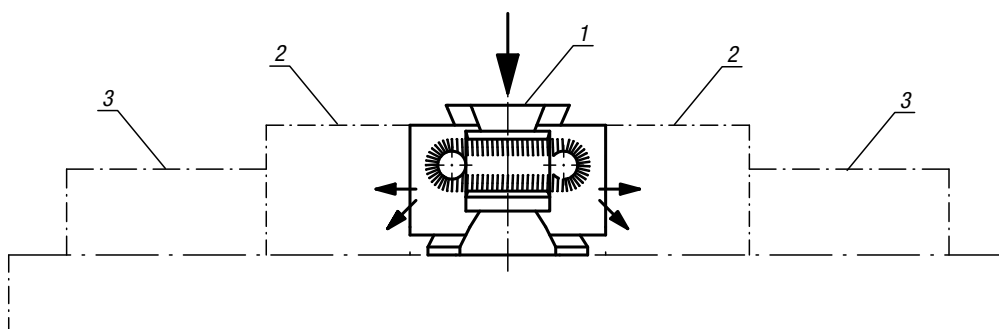
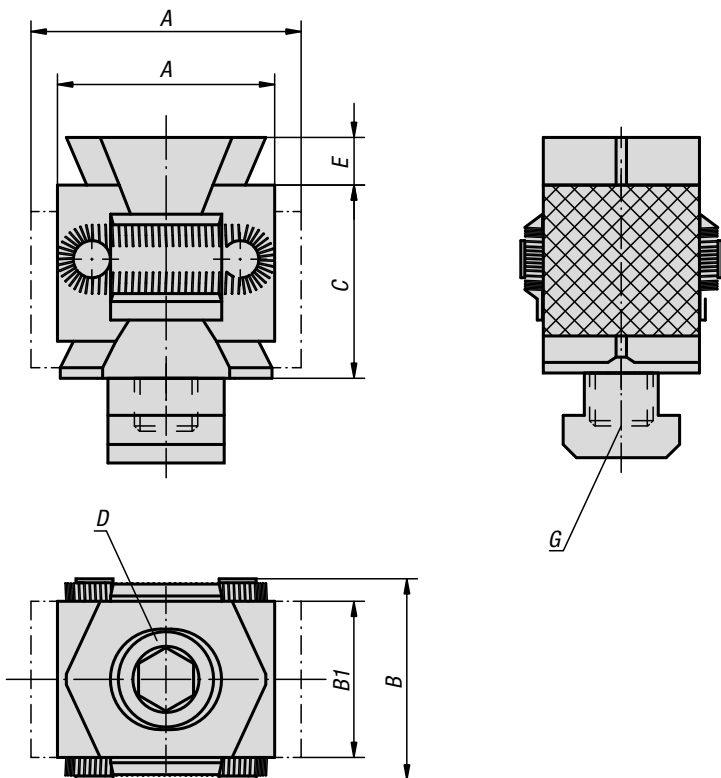

KIPP Wedge clamps double wedge, jaw faces serrated

Order No.	A min.	A max.	B	B1	C	D	E	Version 2	G	Clamping force max. kN	Tightening torque max. Nm
K0042.12	42	49	41	30	36	M12X60	5	for tapped hole	M12	40	85
K0042.1214	42	49	41	30	36	M12X50	5	for t-slot	14	40	85
K0042.16	57	67	56	42	50	M16X80	5	for tapped hole	M16	60	210
K0042.1618	57	67	56	42	50	M16X70	5	for t-slot	18	60	210