

Wedge clamps

jaw faces serrated

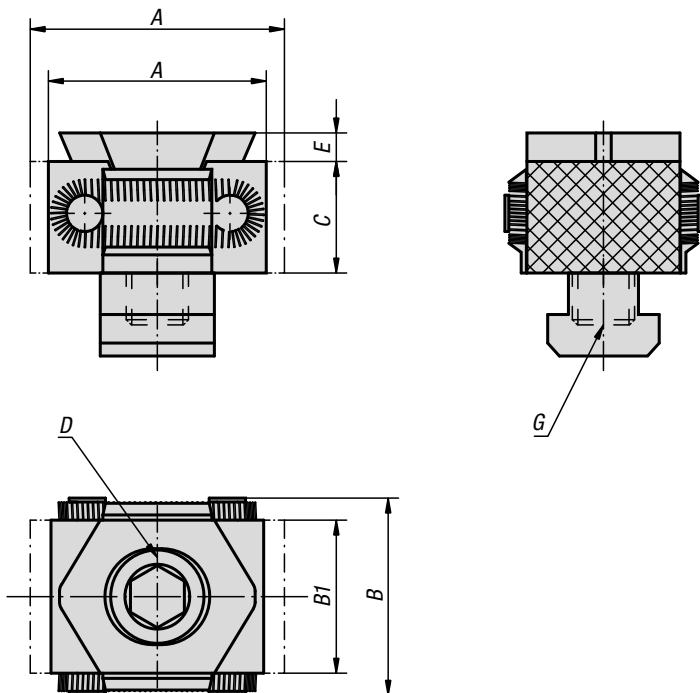

Material:

Body and clamping segments tool steel.

Version:

Body hardened.
Jaw segments hardened (49-51 HRC) black oxidised.
Wedge faces ground.

Sample order:

K0040.1618

Note:

The compact design makes these wedge clamps ideal for horizontal and vertical series clamping. The hardened and ground wedge faces can exert high clamping forces. These wedge clamps can be mounted in grid holes or T-slots. Tightening the DIN 912 socket screw moves the wedge down and the jaws out pressing the workpieces against the fixtures fixed stops.

The jaws of version K0040.08 and K0040.0810 are not serrated.

The wedge has a slightly elongated hole allowing for movement.

Spread width:

K0040.08 = ±0.5 mm
K0040.12 = ±1.0 mm
K0040.16 = ±1.5 mm.

Drawing reference:

D) DIN 912 cap screw

- 1) Wedge clamps
- 2) Workpiece
- 3) Fixed stop

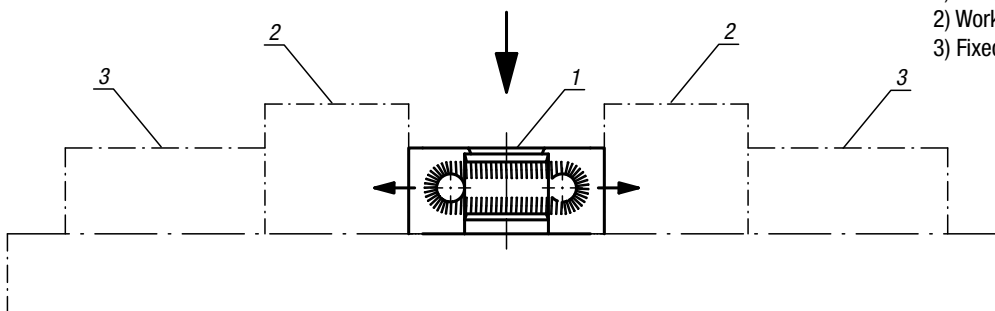

KIPP Wedge clamps, jaw faces serrated

Order No.	Version 1	A min.	A max.	B	B1	C	D	E	Version 2	G	Clamping force max. kN	Tightening torque max. Nm
K0040.08	smooth	27	31	29	21	15	M8X25	2,5	for tapped hole	M8	15	25
K0040.0810	smooth	27	31	29	21	15	M8X25	2,5	for t-slot	10	15	25
K0040.12	serrated	42	49	41	30	22	M12X40	4	for tapped hole	M12	30	85
K0040.1214	serrated	42	49	41	30	22	M12X30	4	for t-slot	14	30	85
K0040.16	serrated	57	66	56	42	29	M16X60	5	for tapped hole	M16	50	210
K0040.1618	serrated	57	66	56	42	29	M16X50	5	for t-slot	18	50	210