

## Side clamps

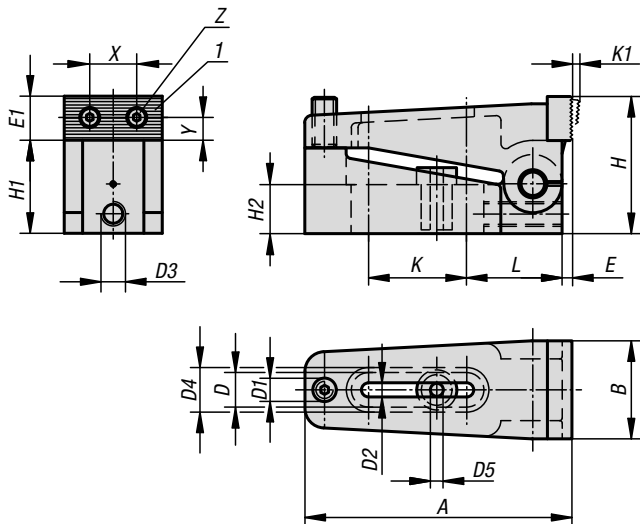

**Material:**

Body steel.  
Jaw mild steel.  
Centring bush carbon steel

**Version:**

Black oxidised.  
Jaw plates case-hardened.

**Sample order:**

K0033.006

**Note:**

The jaws are reversible - smooth side for machined surfaces, serrated side for rough surfaces. A positive down force is also exerted during clamping.

**Drawing reference:**

1) reversible jaw

### KIPP Side clamps

Order No.	A	B	D	D1	D2	D3	D4	D5	E	E1	H	H1	H2	K	K1	L	X	Y	Z	F=Retaining force N
K0033.006	73	25	12,2	M6	7	M6	16	6,5	2,5	11	35	24	12,4	25,5	2,5	27	12	4,5	M3	10000
K0033.010	110	39	18,2	M10	11	M10	24	10,5	4	18	56	38	20	40,5	4	39	20,5	8	M5	40000
K0033.016	170	58	26,2	M16	17	M10	35	17	7	27	85	60	30	60,5	7	61	32	13	M8	100000