

Toe clamps for T-slots

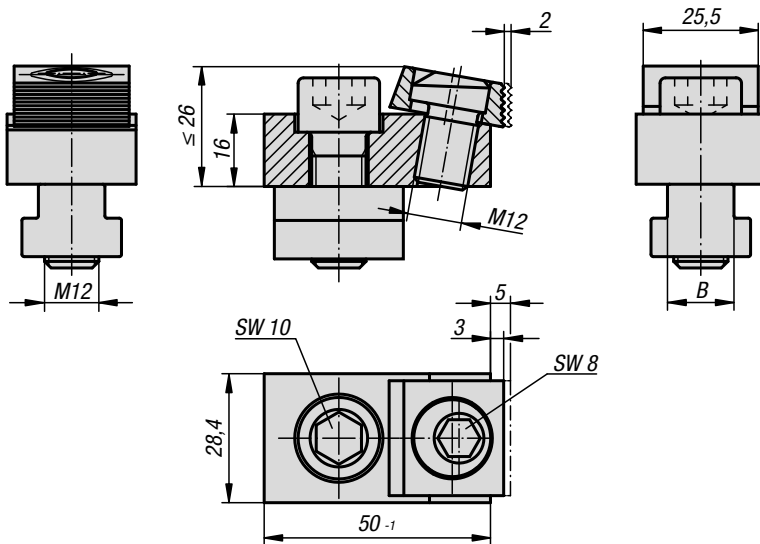

Material:
Steel.

Version:
Body tempered and black oxidised.
Square washer case hardened and brass-plated.

Sample order:
K0029.14

Note:
These toe clamps can be used on machine tables or adapter plates. The positive down force holds the workpiece down on the supporting surface. The square washer can adapt slightly to an angular position i.e. the workpiece does not have to be exactly parallel. The clamping washer has a smooth side for machined surfaces and a serrated side for rough faces.

On request:
Replacement cam screws.

KIPP Toe clamps for T-slots

Order No.	B Slot width	Clamping force kN
K0029.00	without slot key	18
K0029.14	14	18
K0029.16	16	18
K0029.18	18	18