

Spiral cam screws



Material:
Steel.

Version:
Case-hardened (56 ± 1 HRC) and blue electro zinc-plated.
Grade 8.8

Sample order:
K0024.0408

Note:
Robust, compact spiral cam clamping screws that exert a positive down force on diverse workpiece forms.

Assembly:
Drill and tap several holes at a distance X or Z (see diagram). Screw the cam screw into the required height and position with the flat side to the workpiece. Position the workpiece and tighten the cam screw with a hexagon key. Full clamping is achieved with approximately a 1/3 rotation. Lubricate the tapped hole regularly.

Place stops on the face towards which the screw turns to prevent the workpiece rotating away.

On request:
Spiral cam screws with LH thread.

Drawing reference:
1) clamping sheet metal
2) clamping round parts

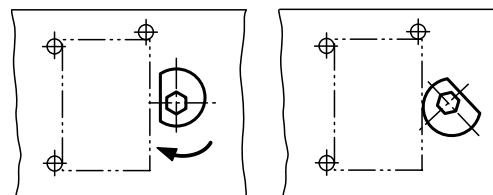
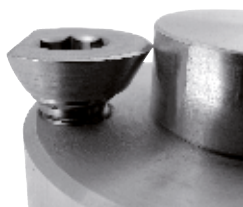
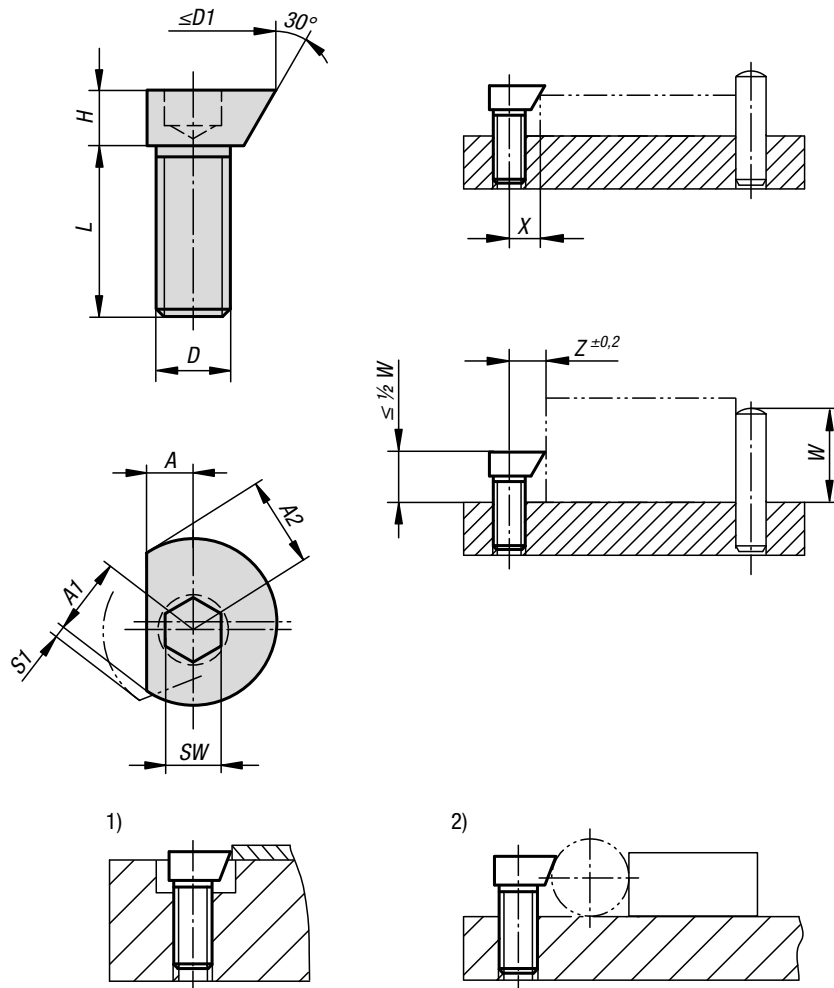

KIPP Spiral cam screws

Order No.	A	A1	A2	D	D1 max.	H	L	SW	S1 (travel)	X	Z	Clamping force kN	Tightening torque max. Nm
K0024.0408	3	4,6	4	M4	9,2	3	8	2,5	0,6	3,5	4,2	0,09	1,5
K0024.0510	3,5	5,7	5	M5	11,4	4	10	3	0,7	4,2	5,2	0,1	2
K0024.0612	4,5	7,1	6,1	M6	14,2	5	12	4	1	5,4	6,4	0,3	4,5
K0024.0816	5,5	8,9	7,7	M8	18	6	16	5	1,2	6,6	8	2,7	20
K0024.1020	6,5	11,1	9,4	M10	22,2	7	20	6	1,7	8,3	9,8	4	30
K0024.1224	8	13,5	11,6	M12	27	9	24	8	1,9	10,1	12	5,4	44