

Swing clamps

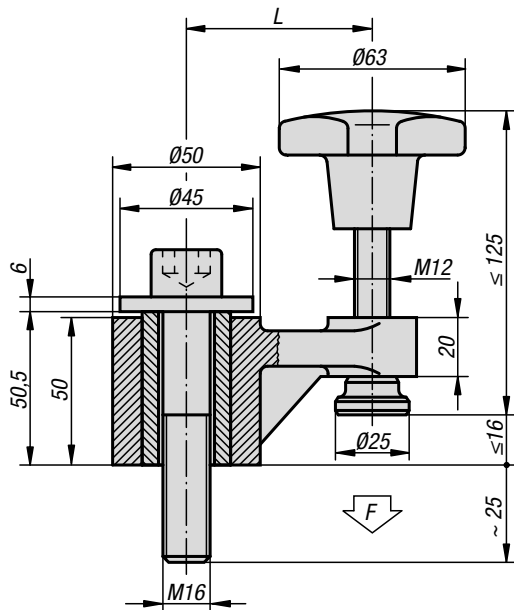

Material:

Body malleable iron.
 Sleeve carbon steel 1.1191.
 Screw carbon steel 1.1181.
 Thrust pad mild steel 1.0301.

Version:

Painted.
 Thrust pads case-hardened.

Sample order:

K0019.01

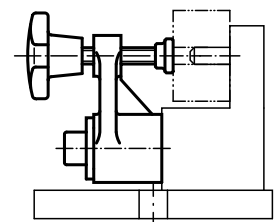

KIPP Swing clamps

Order No.	L	Clamping force N
K0019.01	63	5000
K0019.02	100	3000