

Southco® Hinges

Positioning-Advantage Hinge

- Holds doors open without secondary mechanical support
- Detent holds door closed, and open at 120° and 170°
- Free-swinging style available
- Snap-on covers conceal mounting hardware

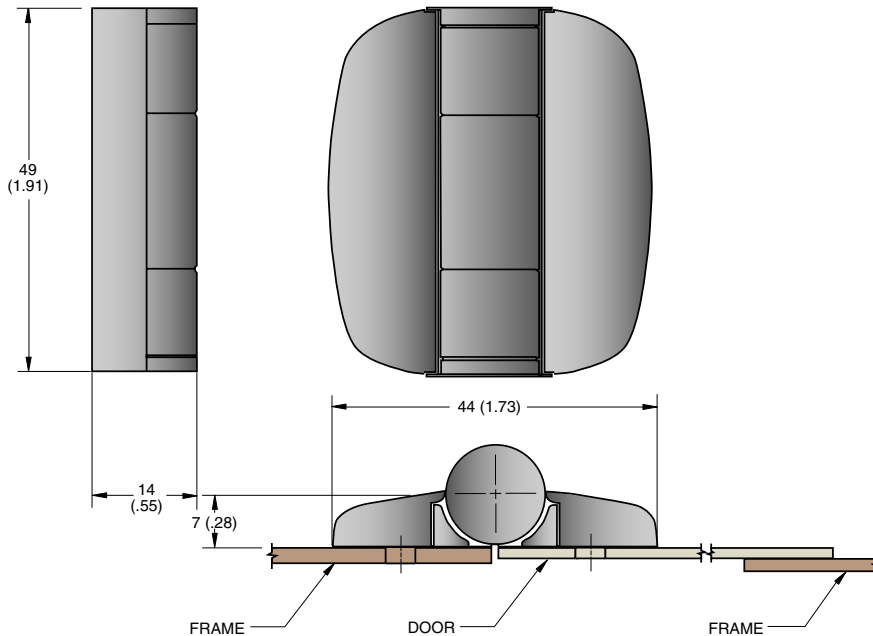

Installation

1. Prepare installation holes as shown.
 2. Mount hinge subassembly with appropriate fastening hardware (not supplied). Maximum recommended tightening torque = 2.2 N·m (20 in·lbs).
 3. Snap covers in place to conceal mounting hardware.
- Hinge subassemblies and covers are designed to accommodate M4 or No. 8 size Pan Head mounting hardware (not supplied).

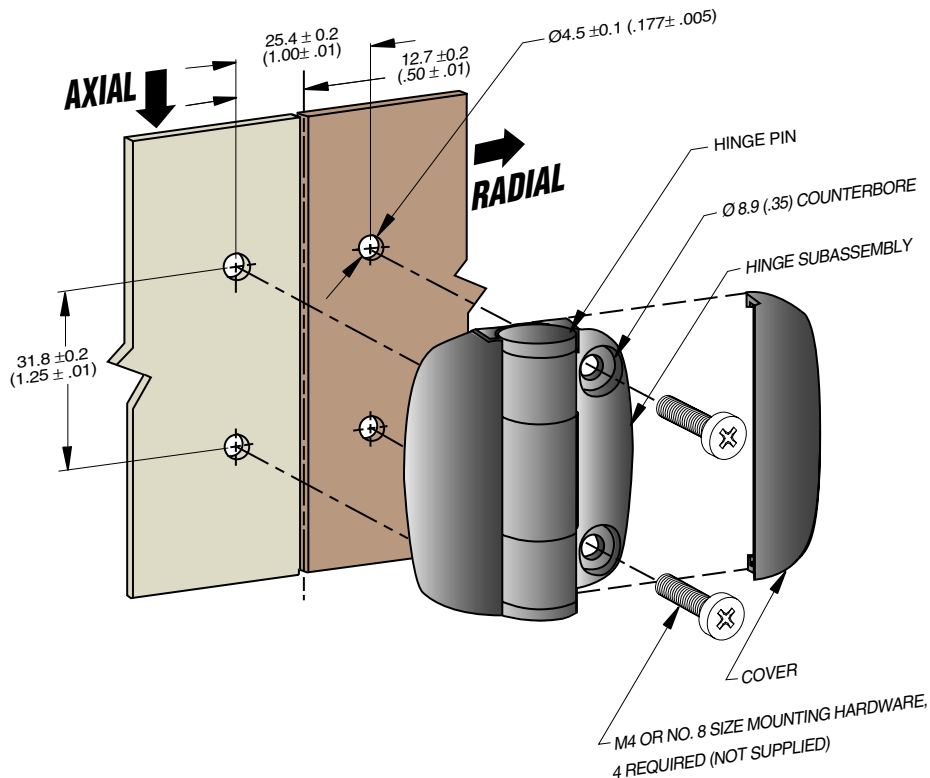

Material and Finish

LEAVES AND COVERS: Nylon, black.
 HINGE PIN AND HINGE PIN INSERT:
 Acetal, black.
 SPRING: Urethane rubber, black.
Flammability Rating: UL94-HB
Operating Temperature Range:
 -20 °C (0° F) To 80° C (180° F)

PART NUMBERS	DETTENTED OPEN ANGLE
G6-5-1 •	170° 120°
G6-0-1 •	FREE-SWINGING (NO DETENTS)

Product Strength Guidelines

(To assist in your product selection; samples are available for your evaluation.)

RADIAL

Maximum static load - 130 N (30 lbs.)
 Average ultimate load - 970 N (220 lbs.)

AXIAL

Maximum static load - 130 N (30 lbs.)
 Average ultimate load - 1450 N (325 lbs.)

CYCLE LIFE: 10,000 cycles

POSITIONING TORQUE : 1.1 N·m
 (10 in·lbs.)

millimeter (inch)
 millimeter
 (inch)

Dimensions without tolerances are for reference only.