

# Southco® Handles and Pulls

## Concealed Pulls

- Pulls can be concealed for a flush surface
- Enclosed housing
- Three sizes

10 series (Small size)

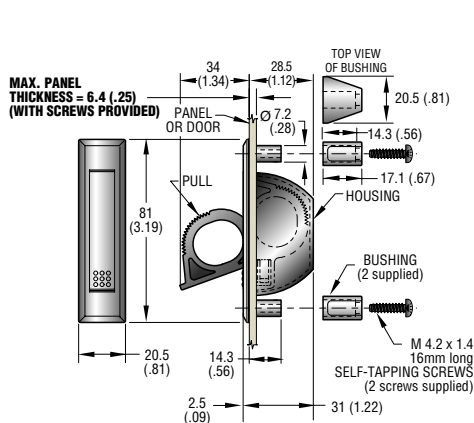

20 series (Medium size)

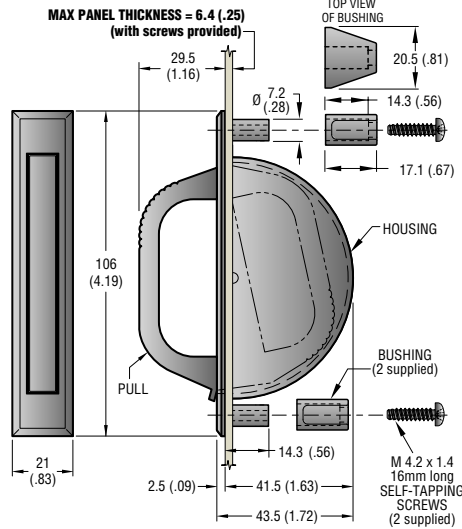

40 series (Large size)

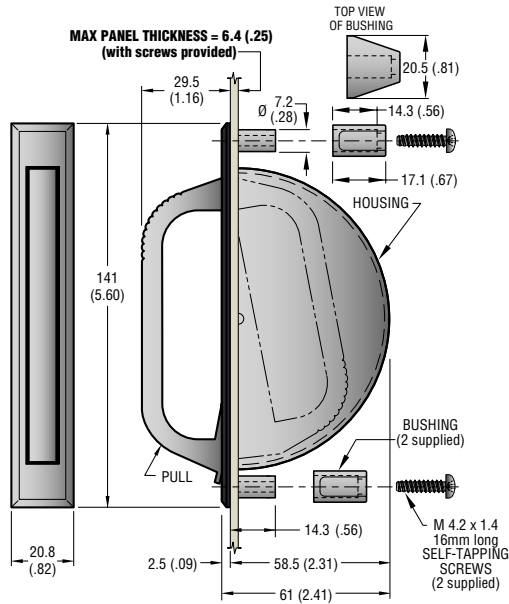

## Panel preparation

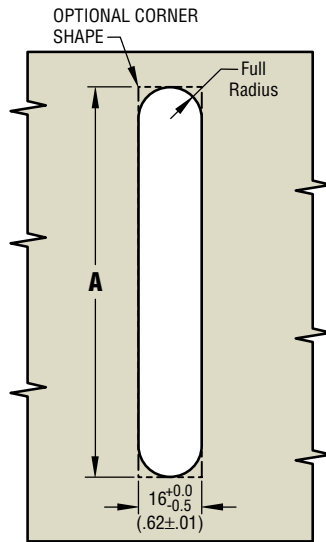

## Material and Finish

### 10 series

HANDLE: PC/PBT Blend, black.

HOUSING: Nylon, black.

BUSHING: Acetal, black.

SCREWS: 302 Stainless steel, passivated.

PIN: 303 Stainless steel, passivated.

### 20 and 40 series

HANDLE: 6063 Aluminum, satin silver or black powder coated.

HOUSING: Nylon, black.

BUSHING: Acetal, black.

SCREWS: 302 Stainless steel, passivated.

PIN: 5056 Aluminum, black anodize.

SPRING: 302 Stainless steel, passivated.

## Installation

1. Prepare Panel.
2. Insert assembly into panel opening, locating serrated section at the top when pull is open.
3. Slide bushings over bosses on back of housing. Run screws into bosses and tighten.  
**NOTE:** Maximum tightening torque of mounting screws: 0.5 N•m (5 in.- lbs.).

## Flammability Rating

HOUSING AND BUSHING: UL94-HB

(10 Series only) HANDLE: UL94-V2

## Operating Temperature Range

[10 Series] -20°C (0°F) to 65°C (150°F)

[20 and 40 Series] -20°C (0°F) to 80°C (180°F)

## Custom Colors!

Contact Southco for details.

millimeter (inch)  
millimeter  
(inch)

Dimensions without tolerances are for reference only.

SERIES (size)	PART NUMBERS		INSTALLATION <b>A</b>	PRODUCT STRENGTH GUIDELINES (To assist in your product selection; samples are available for your evaluation.)	
	Silver handle	Black handle		Maximum recommended static load	Average ultimate load
10 series (small)	—	67-10 •	76 <sup>+1.0</sup> <sub>-0.0</sub> (3.00 <sup>+04</sup> <sub>-.00</sub> )	620 N (140 lbs.)	850 N (190 lbs.)
20 series (medium)	67-27	67-25 •	102 <sup>+1.0</sup> <sub>-0.0</sub> (4.00 <sup>+04</sup> <sub>-.00</sub> )	440 N (100 lbs.)	710 N (160 lbs.)
40 series (large)	67-47	67-45 •	136 <sup>+1.0</sup> <sub>-0.0</sub> (5.35 <sup>+04</sup> <sub>-.00</sub> )	580 N (130 lbs.)	800 N (180 lbs.)