

# Southco® Handles and Pulls

## Pocket Pull Series, Flush Pull (Snap-in Style)

- **UL 94-V0 version now available**
- **For lifting or pulling**
- **Lifting load is transferred directly to panel edge**
- **Single-hole, snap-in installation**
- **Two sizes**

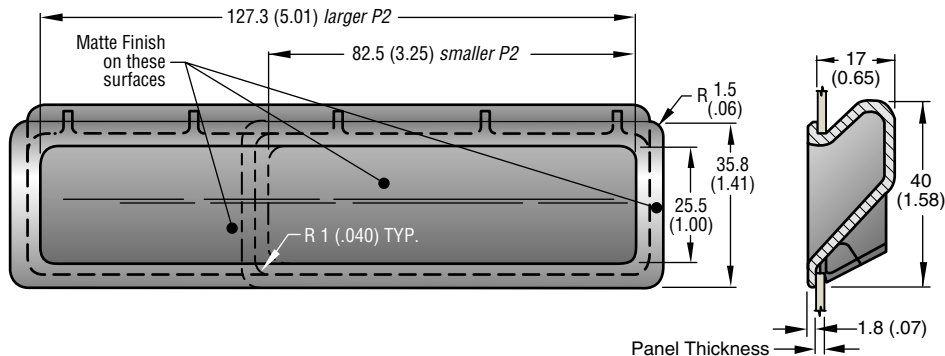

### Material and Finish

ABS, low gloss black.

### Installation

1. Prepare a rectangular opening as shown.
2. Engage edge of opening under flange of pull.

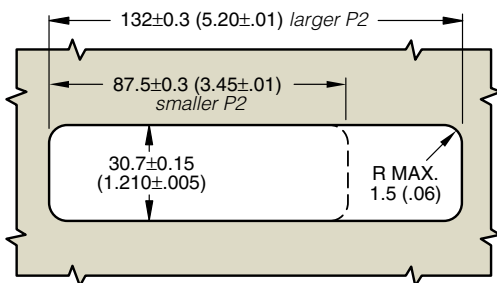

3. Firmly snap in opposite flange with a rocking motion.

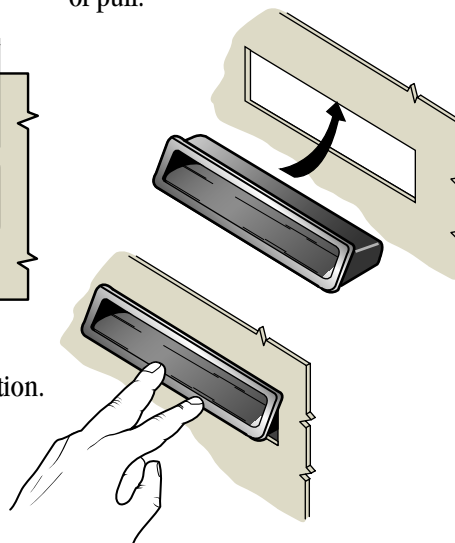

### Product Strength Guidelines

(To assist in your product selection; samples are available for your evaluation.)

(forces applied as shown)

\*Based on installation in 1.2mm (.048) steel panel.  
Maximum loads limited by panel strength.

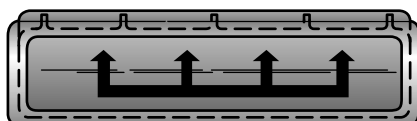

Maximum static load\* = 1800 N (400 lbs.)  
Average ultimate load\* = 5300 N (1200 lbs.)

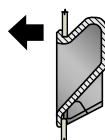

Maximum static load\* = 450 N (100 lbs.)  
Average ultimate load\* = 650 N (150 lbs.)

millimeter (inch)  
millimeter  
(inch)

**Flammability Rating:** UL94 - V0  
or UL94 - HB

**Operating Temperature Range:**  
-50°C (-60°F) to 60°C (140°F)

Dimensions without tolerances are for reference only.

### UL 94-V0

PART NUMBERS		PANEL THICKNESS	
Large	Small	MIN.	MAX.
P2-51-1 •	P2-41-1 •	1 (.040)	1.4 (.055)
P2-52-1 •	P2-42-1 •	1.4 (.055)	1.8 (.070)
P2-53-1 •	P2-43-1 •	1.8 (.070)	2.1 (.085)
P2-54-1 •	P2-44-1 •	2.1 (.085)	2.5 (.100)

### UL 94-HB

PART NUMBERS		PANEL THICKNESS	
Large	Small	MIN.	MAX.
P2-51 •	P2-41 •	1 (.040)	1.4 (.055)
P2-52 •	P2-42 •	1.4 (.055)	1.8 (.070)
P2-53 •	P2-43 •	1.8 (.070)	2.1 (.085)
P2-54 •	P2-44 •	2.1 (.085)	2.5 (.100)

Pulls are shipped bulk.