



Werkstoff:

GJL 250 geblüht oder
Al Zn Mg Cu 1,5 F 50-52.

Bestellbeispiel:

nlm 01160-05 x 300
(Maß L mit angeben)

Bearbeitete Flächen:
± 0,25 mm

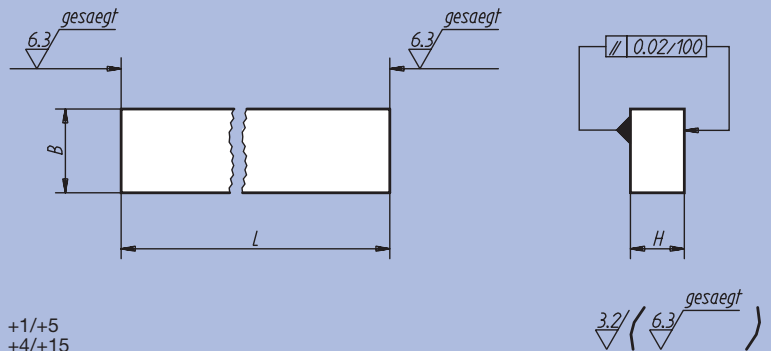

Längentoleranzen:

≤ 200 mm: +1/+5
von 201 mm bis 400 mm: +4/+15
> 400 mm: +13/+40

Bestellnummer GG	Bestellnummer Al	L = Länge				B	H	kg, L/100	
								GG	Al
01160-02 x	01160-202 x	-	-	-	300	32	20	0,5	0,17
01160-03 x	01160-203 x	-	-	-	300	40	25	0,7	0,24
01160-04 x	01160-204 x	-	800	600	300	50	32	1,2	0,40
01160-05 x	01160-205 x	-	800	600	300	63	40	1,8	0,60
01160-06 x	01160-206 x	1000	-	600	300	80	50	2,9	1,00
01160-07 x	01160-207 x	1000	-	600	300	100	63	4,5	1,54
01160-08 x	01160-208 x	-	-	600	300	125	80	7,2	2,47

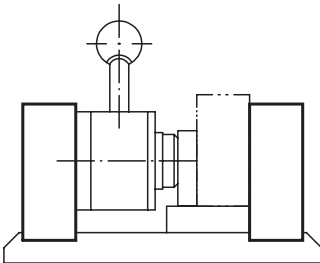

Werkstoff:

GJL 250 geblüht.

Bestellbeispiel:

nlm 01180-03

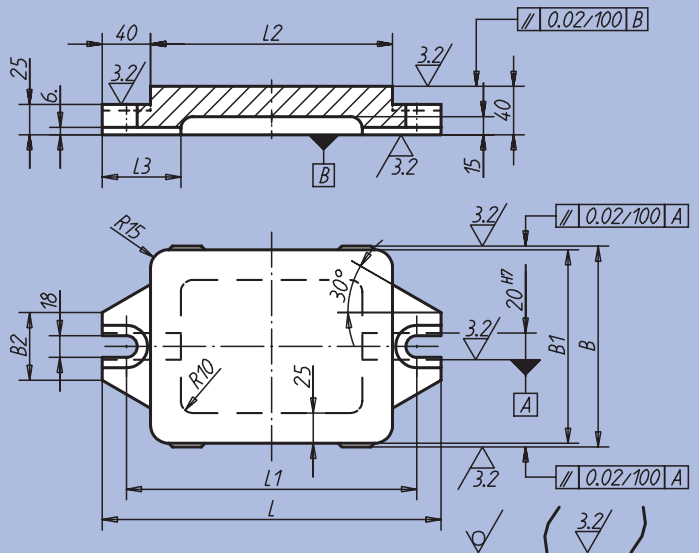

Bestellnummer	L	L ₁	L ₂	L ₃	B	B ₁	B ₂	kg
01180-01	240	200	160	65	166	160	56	7,0
01180-02	280	240	200	65	166	160	56	8,4
01180-03	330	290	250	70	206	200	74	12,5
01180-04	395	355	315	75	256	250	74	18,6

