

Aluminium

Countersunk head
Round shank
Closed

UFX

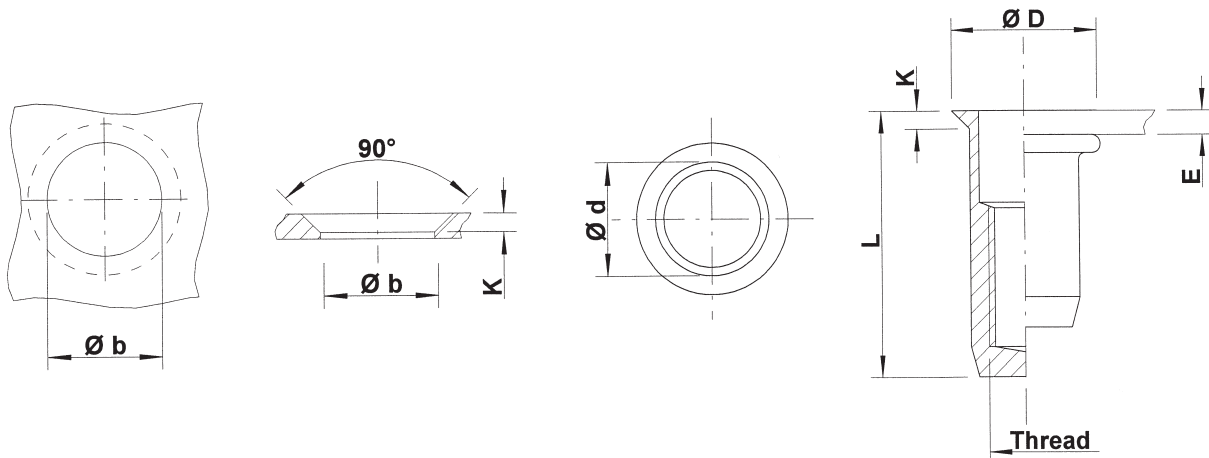

THREAD	TYPE	E = grip	L	b ^{+0,1} = drill dia	d = shank dia	D	K	kg/1000	ORDER CODE
M4	UFX35	1,7-3,5	15,5	6,0	6,0	9,0	1,5	0,7	514 450*
	UFX50	3,5-5,0	17,0	6,0	6,0	9,0	1,5	0,7	514 475*
M5	UFX40	1,7-4,0	18,0	7,0	7,0	10,0	1,5	1,0	515 375*
	UFX65	4,0-6,5	20,5	7,0	7,0	10,0	1,5	1,1	515 400*
M6	UFX45	1,7-4,5	22,0	9,0	9,0	12,0	1,5	2,1	516 400*
	UFX65	4,5-6,5	24,0	9,0	9,0	12,0	1,5	2,3	516 425*
M8	UFX45	1,7-4,5	25,0	11,0	11,0	14,0	1,5	3,3	518 325*
	UFX65	4,5-6,5	28,0	11,0	11,0	14,0	1,5	3,7	518 350*

* Minimum order quantity required after depletion of stock

All dimensions in mm
Technical data subject to modification

