

Southco® Draw Latches

Adjustable Style

- Adjust to your grip range/latching force
- Non-corrosive materials
- All mounting hardware is concealed when latched

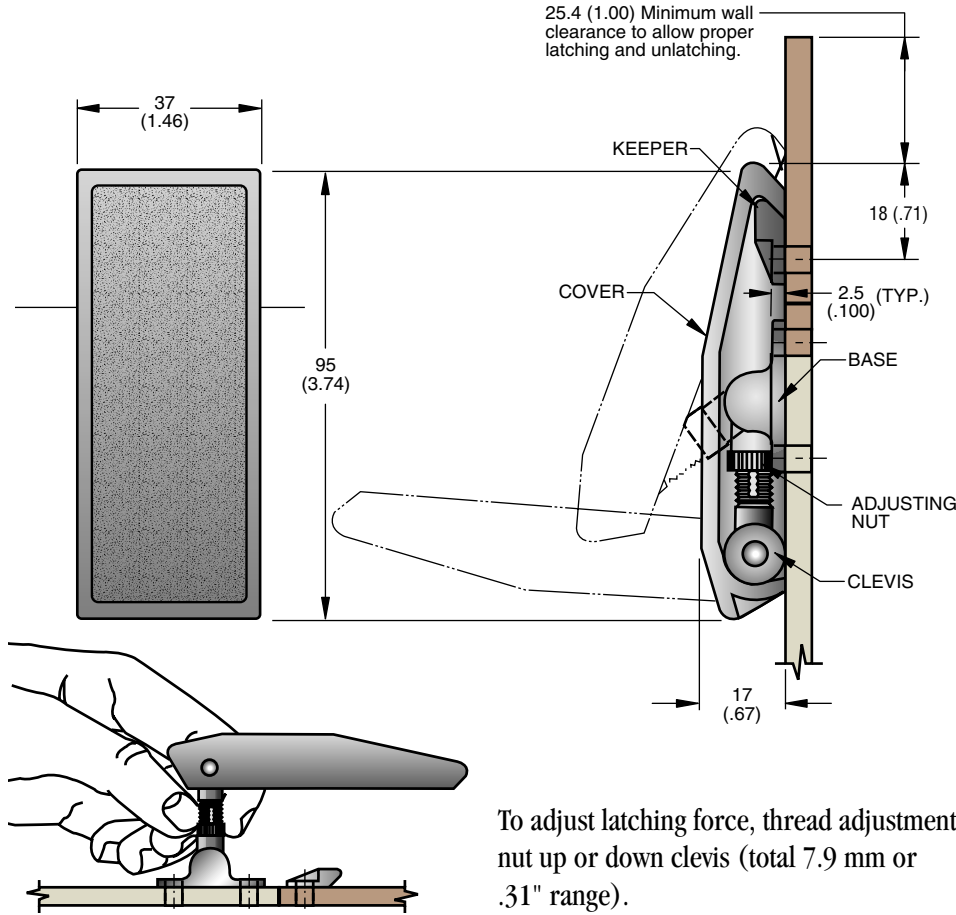

To adjust, simply thread the stainless steel nut up or down the clevis to the desired position...



then, press the cover of the Draw Latch and complete the latching action.



When secured, the latch conceals all of its working parts.

Material and Finish

BASE, CLEVIS, PIVOT NUT and KEEPER: Glass reinforced nylon, black.
COVER and RETAINER: Acetal, black.
ADJUSTMENT NUT: Stainless steel, passivated.

Panel Preparation

Mount with M5 or No. 10 screws or 3/16 diameter rivets.

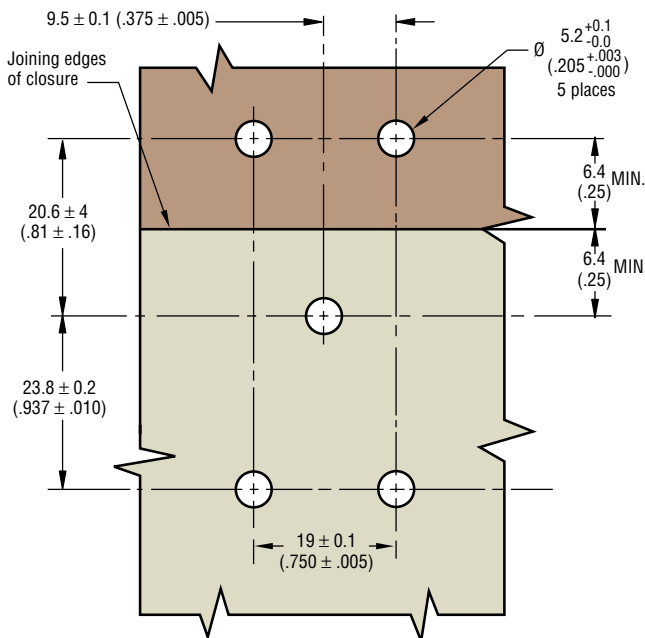

Product Strength Guidelines

(To assist in your product selection; samples are available for your evaluation.)

Maximum static load: 1560 N (350 lbs.)
Average ultimate load: 2220 N (500 lbs.)

Flammability Rating: UL94-HB
Operating Temperature Range: -29°C (-20°F) to 80°C (176°F)

PART NUMBER

E8-10-502-20 •

millimeter (inch)
millimeter (inch)

Dimensions without tolerances are for reference only.