

Southco® Push to Close Latches

Hidden Panel-latching System

- Latches Panels with no visible hardware
- Actuator button is hidden on door edge
- Ejects door as it is being unlatched
- Floating keeper assists alignment
- Steel latch components provide high strength

Push to Close Latches
Concealed

A. Select Keeper:

Floating keeper for hinged panels

Fixed keeper for lift-off panels

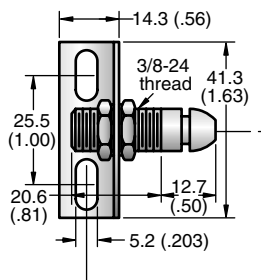
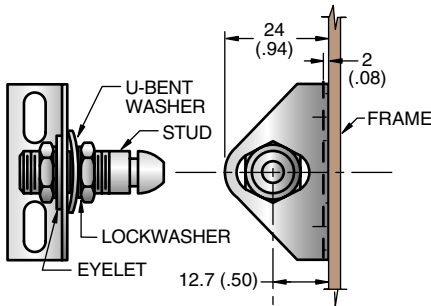

Stud will float 4mm total movement.

B. Determine Latch Location: Near edge or Remote

1. Near edge

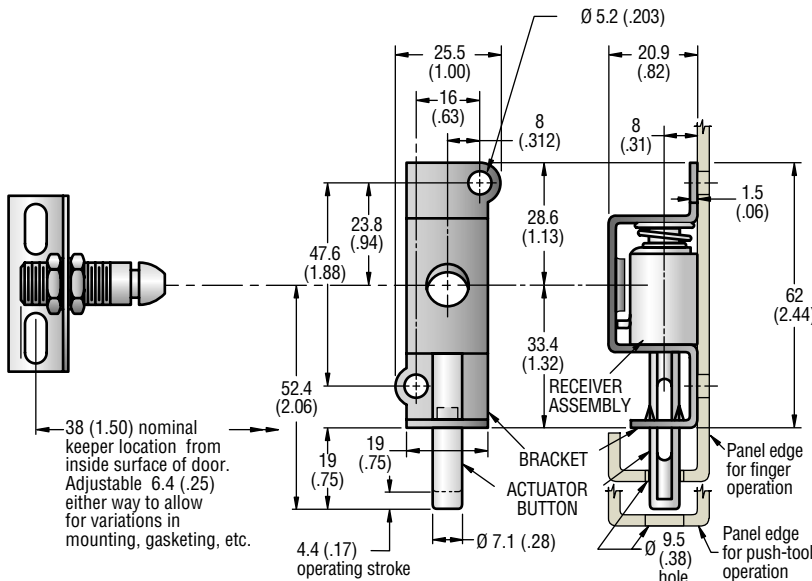

A complete Near edge Assembly comes with keeper.

KEEPER STYLE	ASSEMBLY PART NUMBERS
fixed keeper	E2-50-101-10 •
floating keeper	E2-50-101-20 •

Installation

- 1 Mount brackets on inside surface of your panel using studs, welds, M5 (No.10) screws or Ø5 (.188) rivets.

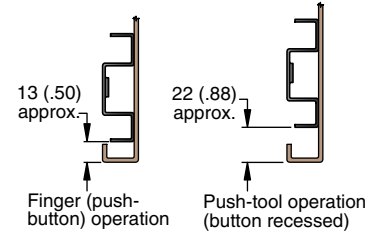

- 2 Slide receiver assembly into side of upper bracket.

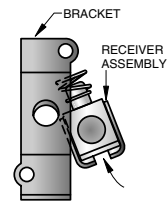

- 3 Remote latching style— Insert extension rod and actuator button into brackets.

Near Edge style— Snap actuator button into bracket.

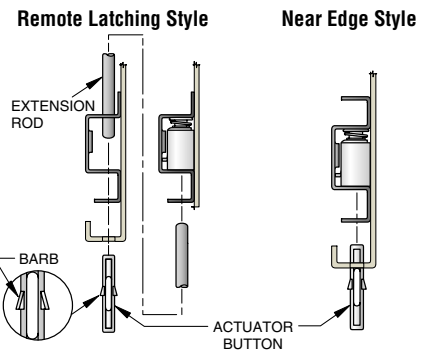

- 4 Mount one or two keepers with M5 (No. 10) screws. Keeper can be adjusted 3.2 (.13) from center both vertically and horizontally for proper alignment with latch.

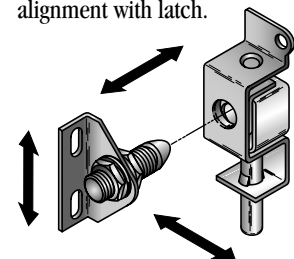

2. Remote latching

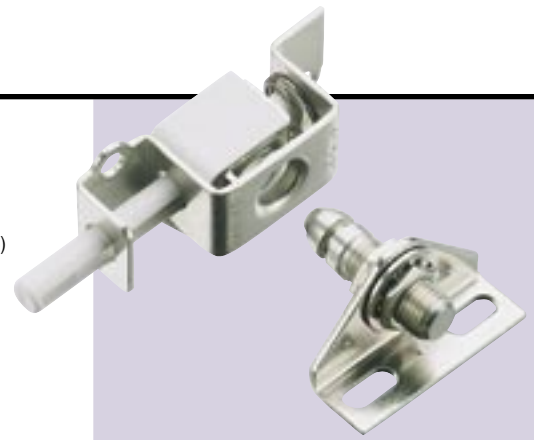
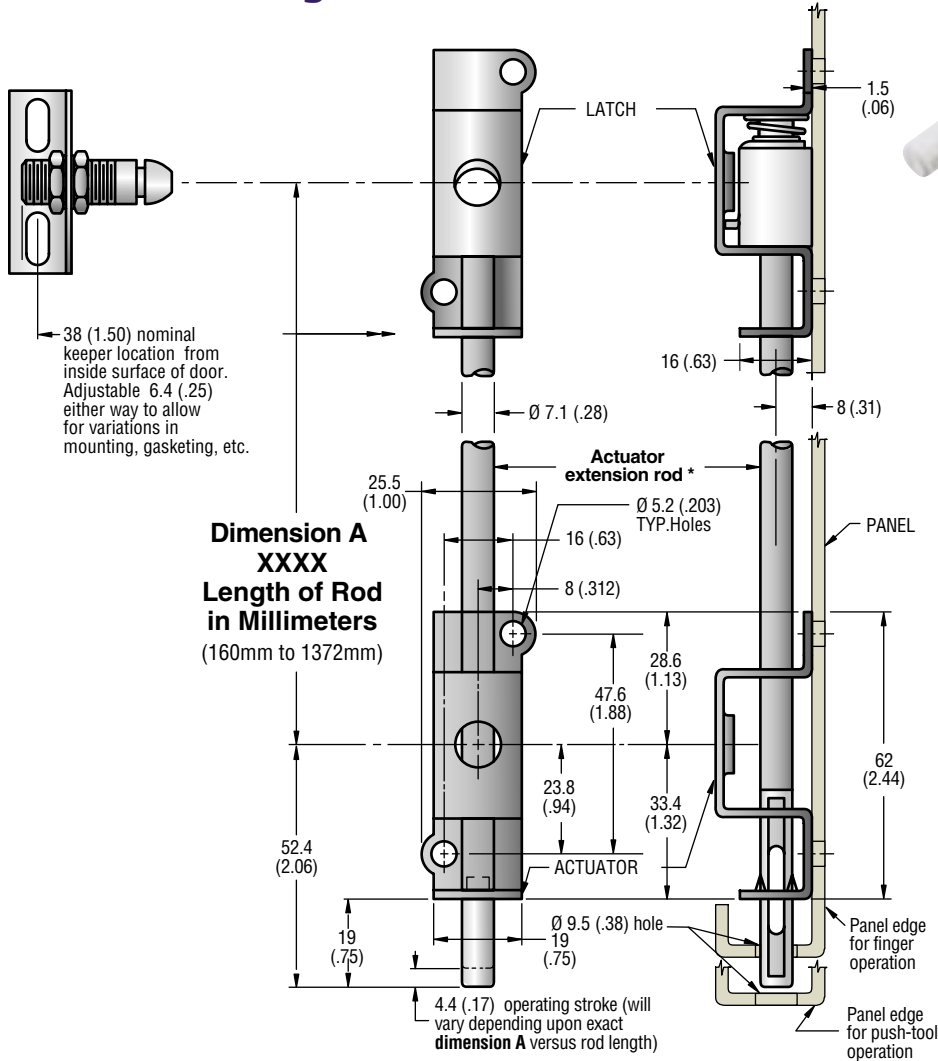

Material and Finish

LATCH, BRACKET, and KEEPER BRACKET: 1010 Steel, zinc plate, chromate plus sealer.
 LATCH PLATE: 1010 Steel, case hardened, zinc plate, chromate plus sealer.
 STUD: 12L14 Steel, case hardened, zinc plate, chromate plus sealer.
 LATCH GUIDE, RECEIVER CUP and ACTUATOR BUTTON: Thermoplastic polyester, white.
 NUTS: Steel, zinc plate, chromate plus sealer.
 LOCKWASHERS: Spring steel, zinc plate, chromate plus sealer.
 U-BENT WASHER: Spring steel, zinc plate.
 EYELET: 12L14 Steel, zinc plate chromate.
 SPRINGS: 302 Stainless steel, natural.

A complete Remote Latch Assembly consists of four components.

A. Select Fixed or Floating Keeper

PART NUMBERS		
A	Floating Keeper	E2-55-102-10
	Fixed Keeper	E2-55-101-10

B. Determine rod part number based on rod length

B	Rod Lengths	
	500 mm	E2-46-0500-16
1250 mm	E2-46-1250-16	

To order rod lengths other than the standard lengths above, use part number E2-46-XXXX-16 (XXXX= length in mm, Min.=160 mm; Max.= 1372 mm). Minimum order: 50 units.

C. & D.

Order an actuator and a Latch Assembly

C	Actuator	E2-91-101
D	Latch	E2-92-101

PRODUCT STRENGTH GUIDELINES (To assist in your product selection; samples are available for your evaluation.)		
Keeper Style	Static load	Ultimate load
Fixed	1300 N (300 lbs.)	2200 N (500 lbs.)
Floating	750 N (170 lbs.)	1400 N (310 lbs.)

Flammability Rating: UL 94 - V-0

Operating Temperature Range:

-18°C (0°F) to 120°C (250°F)

millimeter (inch)
millimeter
(inch)

Dimensions without tolerances are for reference only.

Southco® Multi-point Latching Systems

Hidden Panel-latching System

- Push to close, push the button to open
- For 2-point latching
- Floating keeper accommodates hinged panels
- Fixed keeper accommodates lift-off panels

A Complete Assembly Consists of:

A. Keeper, B. Rod, C. Actuator, D. Latch
Order each component separately.

Floating keeper for hinged panels

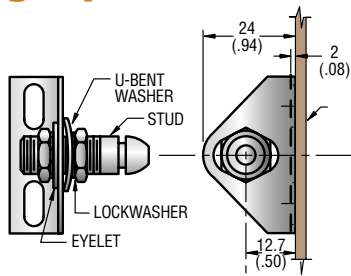

Stud will float 4 (.16) total movement

Fixed keeper for lift-off panels

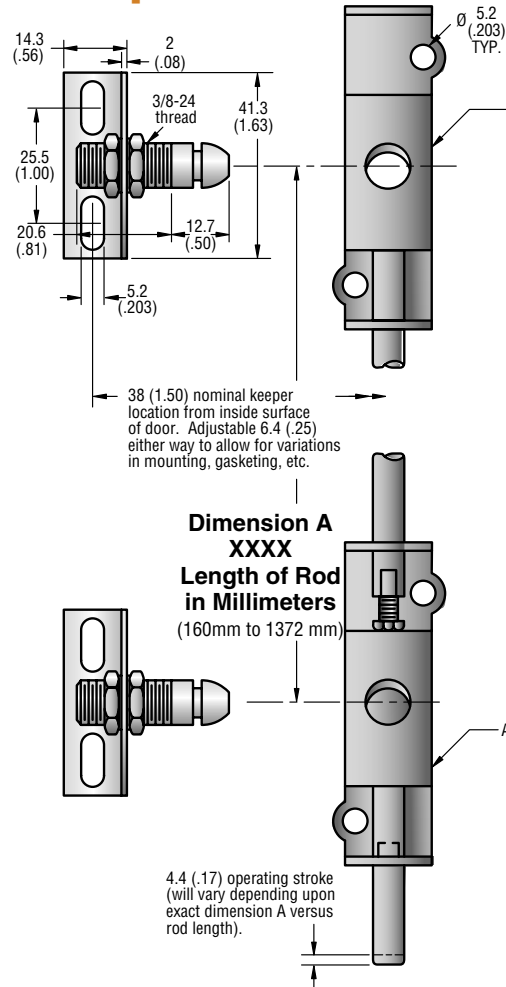

**Dimension A
XXXX**
Length of Rod
in Millimeters
(160mm to 1372 mm)

4.4 (.17) operating stroke
(will vary depending upon
exact dimension A versus
rod length).

A complete 2-point Latch Assembly consists of four components.

PART NUMBERS		
A	Floating Keeper	E2-55-102-10
	Fixed Keeper	E2-55-101-10

Rod length is equal to the distance between keepers minus 30mm.

B	500 mm	E2-42-0500-16
	1250 mm	E2-42-1250-16

To order rod lengths other than the standard lengths above, use part number E2-42-XXXX-16 (XXXX= length in mm, Min. =160 mm; Max.= 1372 mm). Minimum order: 100 units

C	Actuator	E2-93-102
D	Latch	E2-92-102

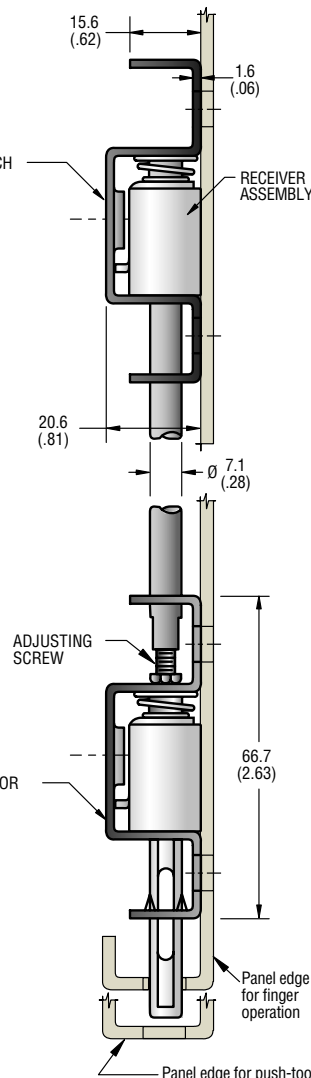

Panel edge for push-tool operation

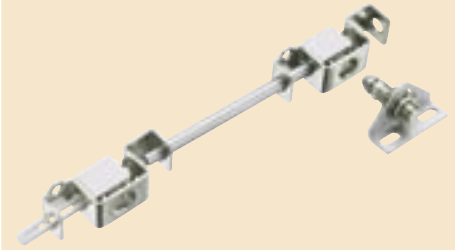

Material and Finish

(2-point Systems)

LATCH, BRACKET, and KEEPER BRACKET: 1010 Steel, zinc plate, chromate plus sealer.
LATCH PLATE: 1010 Steel, case hardened, zinc plate, chromate plus sealer.
STUD: 12L14 Steel, case hardened, zinc plate, chromate plus sealer.
LATCH GUIDE, RECEIVER CUP and ACTUATOR BUTTON: Thermoplastic polyester, white.
NUTS: Steel, zinc plate, chromate plus sealer.
LOCKWASHERS: Spring steel, zinc plate, chromate plus sealer.
U-BENT WASHER: Spring steel, zinc plate.
EYELET: 12L14 Steel, zinc plate chromate.
SPRING: 302 Stainless steel, passivated.
CONICAL SPRING: 302 Stainless steel, natural.
ACTUATOR ROD: Aluminum, natural.
ADJUSTING SCREW: Steel, zinc plated.

PRODUCT STRENGTH GUIDELINES

(To assist in your product selection; samples are available for your evaluation.)

Keeper Style	Static load	Ultimate load
Fixed	1300 N (300 lbs.)	2200 N (500 lbs.)
Floating	750 N (170 lbs.)	1400 N (310 lbs.)

Flammability Rating: UL 94 - V-0

Operating Temperature Range:

-18°C (0°F) to 120°C (250°F)

See page 166 for detailed installation instructions.

millimeter (inch)
millimeter
(inch)

Dimensions without tolerances are for reference only.

Southco® Multi-point Latching Systems

Hidden Panel-latching System

Installation

1 Mount brackets on inside surface of your panel using studs, welds, M5 (No.10) screws or Ø5 (.188) rivets.

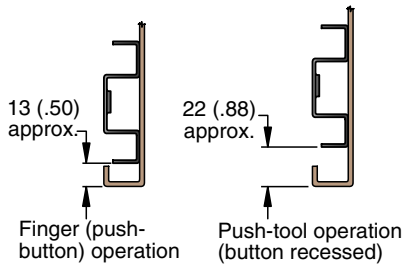

2 Slide receiver assembly into side of upper bracket.

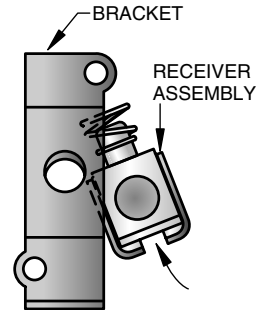

3 Remote latching style- Insert extension rod and actuator button into brackets.

Two-point style- Insert extension rod into brackets then slide receiver assembly into side of lower bracket and snap in actuator button.

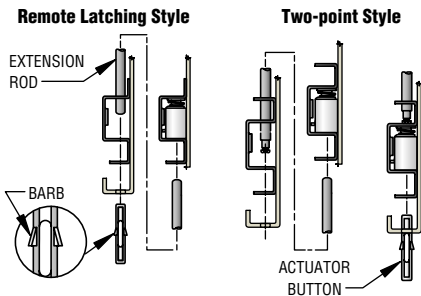

4 Mount keeper with M5 (No. 10) screws. Keeper can be adjusted 3.2 (.13) from center both vertically and horizontally for proper alignment with latch.

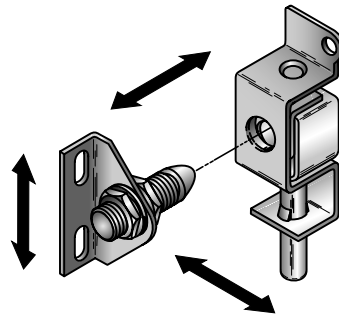

millimeter (inch)
millimeter
(inch)

Dimensions without tolerances are for reference only.