

Southco® Push to Close Latches

Touch Latch, Small Size

- Push the door to latch and unlatch
- Single-hole, snap-in installation
- Self-adhesive keeper
- Nothing shows on the surface

Push to Close Latches
Concealed

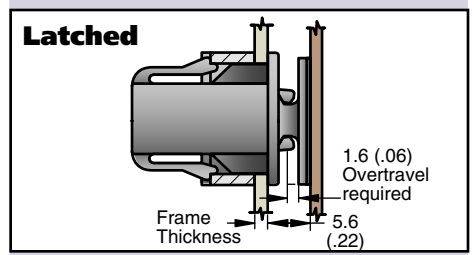
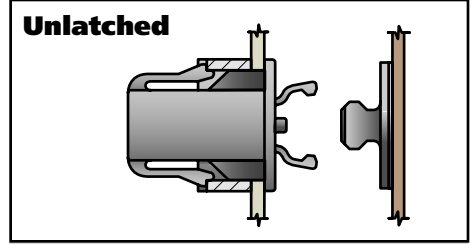
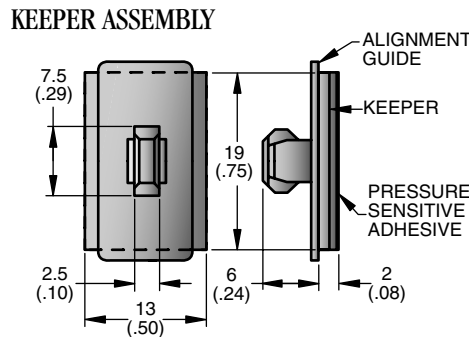
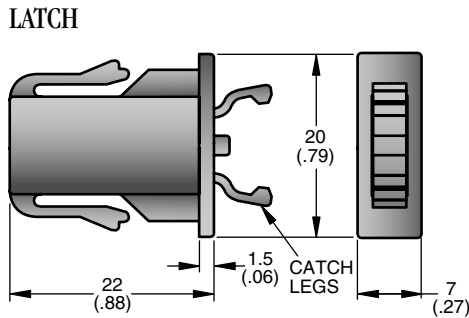
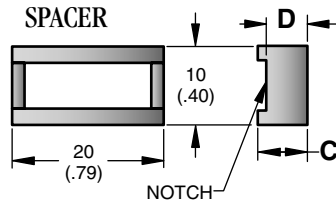

When your frame thickness is:		PART NUMBER	INSTALL SPACER IN POSITION	SPACER THICKNESS		SPACER COLOR
MIN.	MAX.			C	D	
0.8 (.030)	1 (.040)	E4-10-102-10 •	A	7.5 (.295)	6.9 (.270)	Black
1.4 (.055)	1.7 (.065)			B		
1.8 (.070)	2 (.080)	E4-10-103-10 •	A	6.5 (.255)	5.3 (.210)	Natural
2.9 (.115)	3.2 (.125)			B		
4.6 (.182)	4.9 (.192)	E4-10-104-10 •	A	3.6 (.143)	2 (.080)	Gray
6.2 (.245)	6.5 (.255)			B		
8.1 (.320)	8.6 (.340)	E4-10-101-10 •		Spacer not required.		

Installation

1. Prepare frame. Snap latch into place.

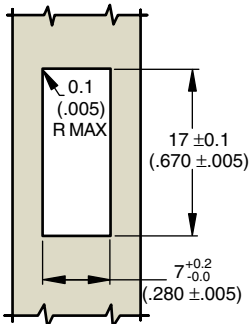

3. With alignment guide in place, engage keeper with latch. (If catch legs are retracted, push them into the latch housing to release before proceeding).

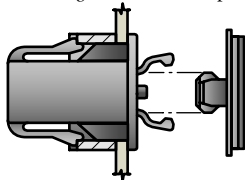

4. Peel protective backing from keeper. Close door against adhesive.

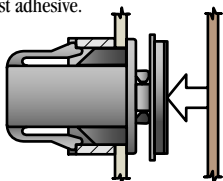

2. Install spacer. (If required).

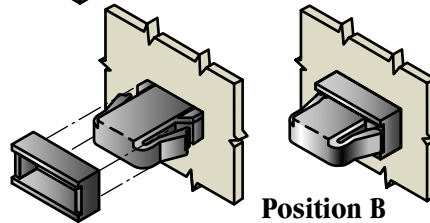
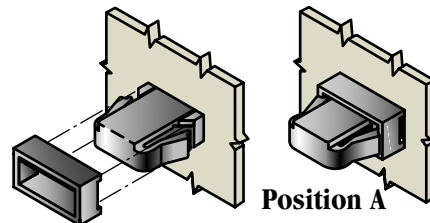

5. Remove alignment guide from keeper and discard.

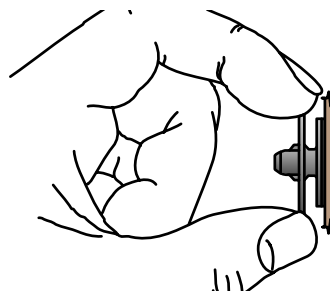

Material and Finish

- LEAF SPRING: Beryllium copper.
- SPRING: 302 Stainless steel, passivated.
- PRESSURE SENSITIVE TAPE: Neoprene foam with acrylic adhesive.
- ALIGNMENT GUIDE: Acetal, white.
- SPACER: Acetal, (see table).
- BALL: Chrome steel.
- OTHER PARTS: Acetal, black.

Product Strength Guidelines

(To assist in your product selection; samples are available for your evaluation.)
Average latch tensile: 15 N (3.5 lbs.)

Flammability Rating: UL94 - HB

Operating Temperature Range:
-40°C (-40°F) to 105°C (220°F)

NOTE: Self-adhesive keepers are designed to function under intermittent break-away loads.

NOTE: Be sure the mounting surface is clean and capable of retaining a satisfactory adhesive bond.

millimeter (inch)
millimeter
(inch)

Dimensions without tolerances are for reference only.

Southco® Push to Close Latches

Touch Latch, Large Size

- Push the door to latch and unlatch
- Single-hole, snap-in installation
- Self-adhesive keeper
- Nothing shows on the surface

LATCH

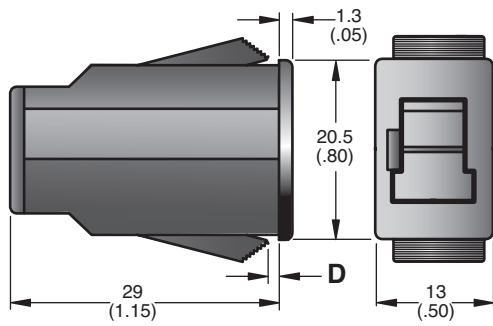

KEEPER ASSEMBLY

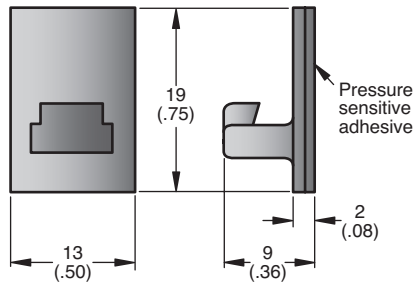

FRAME THICKNESS		D	PART NUMBER
MIN.	MAX.		
1 (.04)	3 (.12)	0.9 (.035)	E4-10-201-10 •
3 (.12)	5 (.20)	2.9 (.115)	E4-10-202-10 •
5 (.20)	7 (.28)	4.9 (.195)	E4-10-203-10



Latched

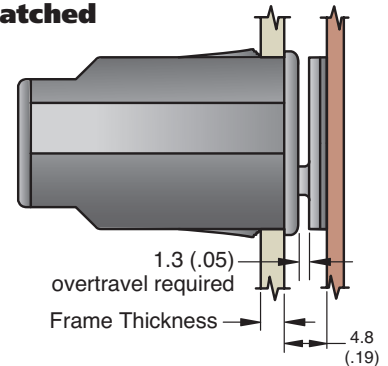

Material and Finish

SPRING: 302 Stainless steel, passivated.
 PRESSURE SENSITIVE TAPE: Neoprene foam with acrylic adhesive.
 HOUSING and COVER: Thermoplastic polyester, black.
 OTHER PARTS: Acetal, black.

Product Strength Guidelines

(To assist in your product selection; samples are available for your evaluation.)

Average latch tensile with:
 Standard adhesive keeper 50 N (11 lbs.)
 Integrally molded keeper 120 N (27 lbs.)

Flammability Rating: UL94 - HB
Operating Temperature Range:
 -40°C (-40°F) to 105°C (220°F)

NOTE: Self-adhesive keepers are designed to function under intermittent break-away loads.

NOTE: Be sure the mounting surface is clean and capable of retaining a satisfactory adhesive bond.

Installation

1. Prepare frame.

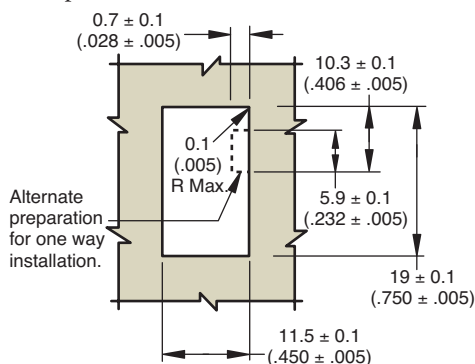

2. Snap latch into place.

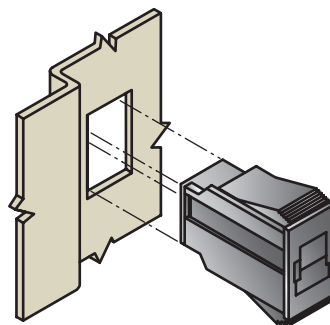

3. Re-engage keeper with latch.

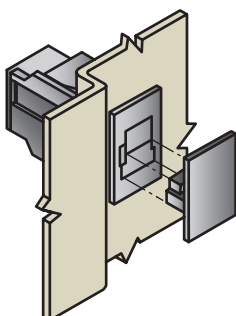

4. Peel protective backing from keeper.
 Close door against adhesive.

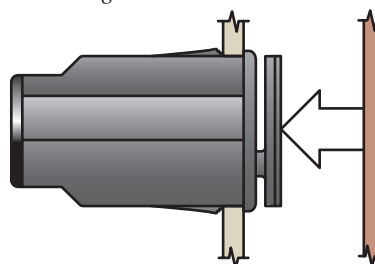

millimeter (inch)
 millimeter
 (inch)

Dimensions without tolerances are for reference only.